

Industrial Lifting Equipment

- ▶ Manual Wire Rope Ratchet Pullers
- ▶ Lever Chain Hoist
- ▶ Manual Chain Hoist
- ▶ Electric Chain Hoist
- ▶ Air Chain Hoist
- ▶ Trolleys

DOBCO
EQUIPMENT LTD

Ontario's Largest
Pneumatic & Hydraulic Tool Distributor

1-2430 Lucknow Drive, Mississauga, Ontario L5S 1V3. Tel: 905-672-5557 Fax: 905-672-5559
Email: sales@dobcoeqp.com www.dobcoeqp.com

Proven Solutions.



IR Ingersoll-Rand
www.irtools.com

Ingersoll-Rand Tool and Hoist Division

Ingersoll-Rand offers one of the broadest lines of lifting equipment available. Our hoists are capable of providing solutions in applications throughout the world. From food processing to mining, automotive assembly to construction, IR hoists can be found in the most demanding industries.

The Ingersoll-Rand manual lifting family includes wire and rope pullers, lever chain powered hoists for excellent spotting or fast production needs.

Ingersoll-Rand also offers a wide variety of plain, geared, or powered trolleys as well as tractors to support and mobilize your Ingersoll-Rand hoist.

Solutions to special applications, such as spark hazard or food processing environments can be accommodated by our manufacturing specialists.

Ingersoll-Rand... the *Proven Source* and *Proven Solution* to your lifting equipment needs.

Hoist Limited Warranty

Ingersoll-Rand Company (I-R) warrants its hoists to be free of defects in material and workmanship for one year from the date of purchase. I-R will repair, without cost, any hoist found to be defective, including parts and labor charges, or at its option, will replace such hoists or refund the purchase price. Repairs or replacements are warranted for the remainder of the original warranty period.

If any I-R hoist proves defective within its original one year warranty period, it should be returned to any Authorized Material Handling Distributor, transportation prepaid with proof of purchase or warranty card.

This warranty does not apply to hoists which I-R has determined to have been misused or abused, improperly maintained by the purchaser; or where the malfunction or defect can be attributed to the use of non-genuine I-R parts.

I-R makes no other warranty, and implied warranties including any warranty of merchantability or fitness for a particular purpose are hereby disclaimed. I-R's liability is limited to the purchase price of the hoists and in no event shall I-R be liable for consequential, indirect, or special damages of any nature arising from the sale or use of I-R hoists.

Note:

Some states do not allow limitations on incidental or consequential damages or how long an implied warranty lasts so that the above limitations may not apply to you. This warranty gives you specific legal rights and you may also have other rights which may vary from state to state.

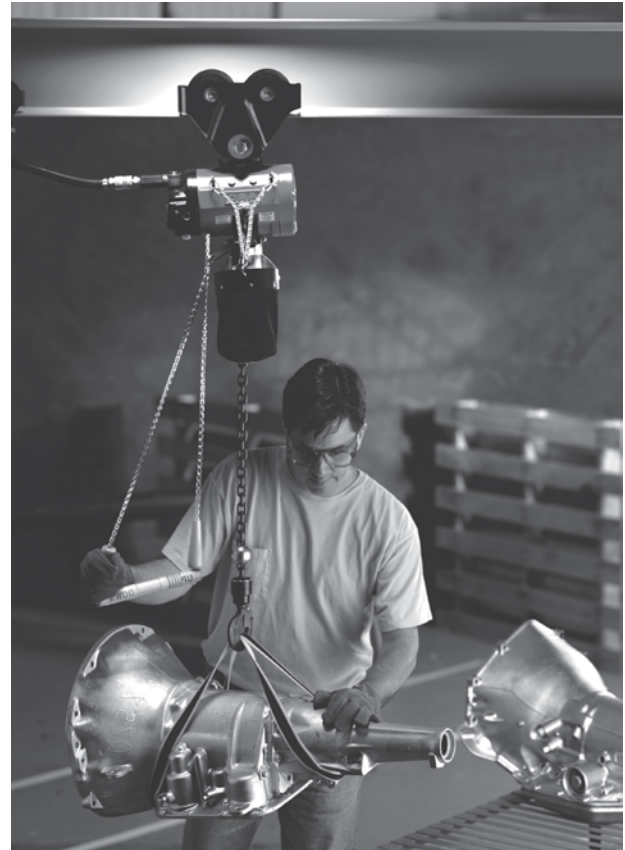

ROUGHNECK™



SILVER SERIES™

PALAIR™ PREMIUM



LO-PRO™

ULTRA-LO™



1000 and 2000 lb Capacity

Features / Wire Puller:

- 4:1 design factor. Meets ASME B30.21.
- Handle and frame are heavy gauge steel with rivet construction and slip-resistant grip. All steel parts are plated for years of useful life.
- Exclusive long life "buttress tooth" cast gear design has no laminated plates to separate or wear and provides maximum strength.
- Sturdy steel drive and holding pawls have long life, stainless steel springs. All pivot points are hardened steel.
- Safety latch hooks are drop forged steel, heat treated and plated for corrosion resistance. Top hook rotates 360° for easy operation.
- Cast-aluminum drum has a "through-the-drum" anchor, larger diameter and a drum guard. This means the wire rope won't come loose, bends less so it lasts longer and spools evenly while rewinding.
- Galvanized aircraft quality wire rope is preformed to prevent kinks.
- One year warranty.

Features / Rope Puller:

- Two models with either 25 or 75 foot rope length.
- Standard with oversized 5/8 inch diameter high strength polyester rope.
- Rope has less chance to mar surfaces or kink and is easier to manage than wire cable.
- Rope is non-conductive and can be stored or used separately.
- Rope pullers can handle long pulls or reaches limited only by the length of rope available.
- The Ingersoll-Rand rope puller is easy to pay out rope and will not bind the rope in the drum after pulling a load.

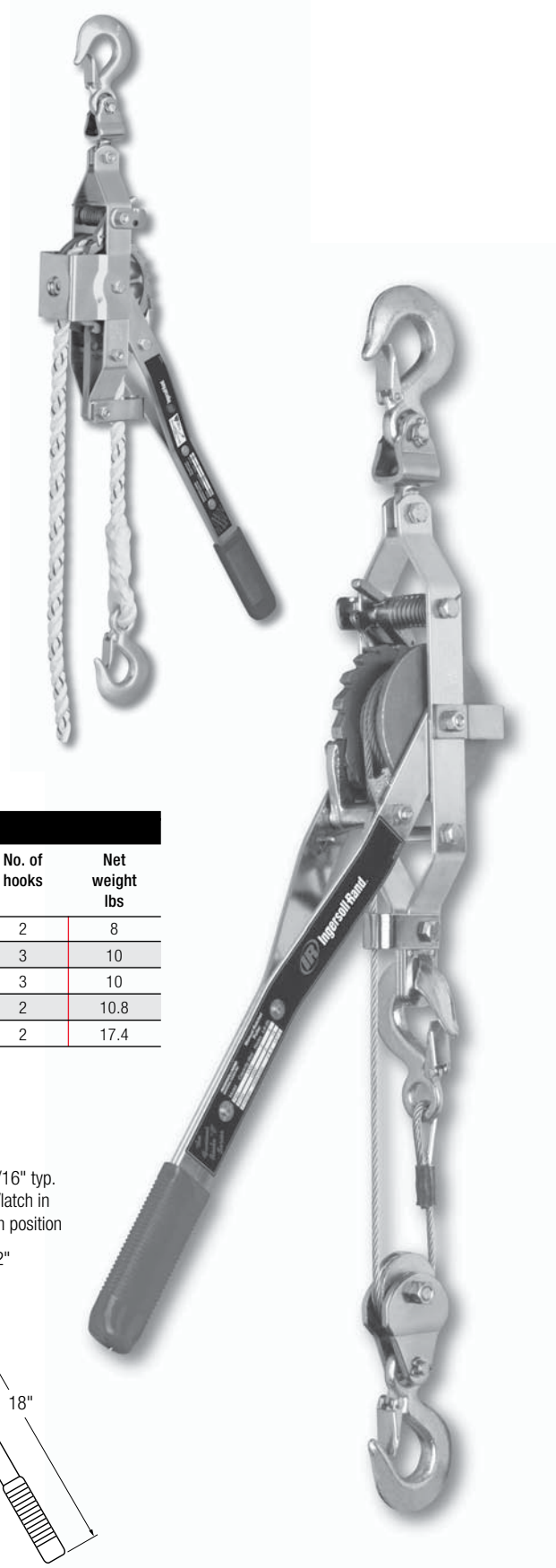

P Series Specifications and Dimensions

Model no.	No. of lines	Rated cap. lifting 4:1 lbs	Min. 'A' dist. btwn hooks in.	Lifting distance ft	Cable diameter in.	No. of hooks	Net weight lbs
P15H	Single	1000	19 1/2	15	3/16	2	8
P15D3H	Single	1000	21	15	3/16	3	10
P15D3H	Double	2000	27 1/2	7 1/2	3/16	3	10
PR-25	Single	1100	24	23	5/8	2	10.8
PR-75	Single	1100	24	73	5/8	2	17.4

Note:
 Dimensions are subject to change.

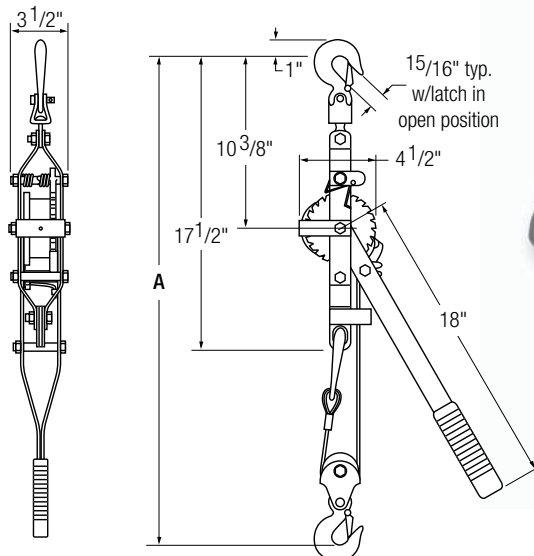

1700 – 4000 lb Capacity

Features / Cable Puller:

- 4:1 design factor lifting, lowering and pulling. Meets ASME B30.21.
- Overload safety handle designed to noticeably bend.
- Lightweight aluminum frame.
- Alloy steel load hook with safety latches.
- One piece cast aluminum drum.
- Buttress tooth design improves load gear life.
- Solid steel drive and holding dog, not laminated plates.
- Galvanized aircraft quality wire rope.
- Ratchet and pawl system provides safe, "one notch at a time" lowering.
- Cable guide and shield protects wire rope and spools cable evenly on drum.
- Reversible handle changes position easily, so pull is always possible in the right direction against the load.
- Easy to repair, replacement parts available.
- Plated external parts for corrosion resistance.

Features / Strap Puller:

An extension of our premium C Series, the C Series strap pullers offer the following unique features:

- Three hooks allow 2 ton capacity; 6 foot pull with double line and 1 ton capacity with 12 foot pull using single line.
- Non-conductive, corrosion resistant, high strength synthetic strap will not kink or bind.
- Easy pay out of strap for fast set-up.

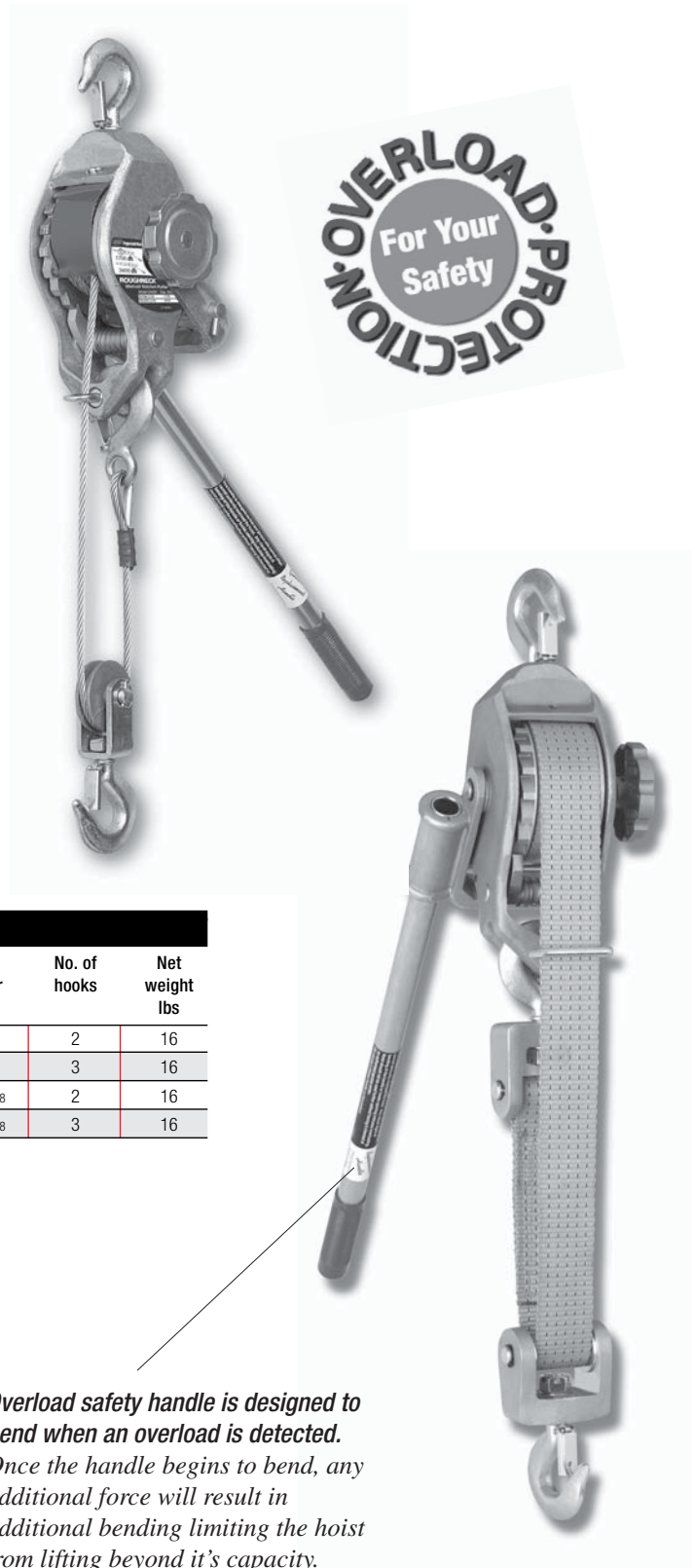

C Series Specifications

Model no.	No. of lines	Rated cap. lifting 4:1 lbs	Min. 'A' dist. btwn hooks in.	Lifting distance ft	Cable diameter in.	No. of hooks	Net weight lbs
C400H	Single	1700	17	20	1/4	2	16
C400H	Double	3400	22	10	1/4	3	16
C400S	Single	2000	17	12	3/32 x 1 7/8	2	16
C400S	Double	4000	22	6	3/32 x 1 7/8	3	16

Note:
Dimensions are subject to change.

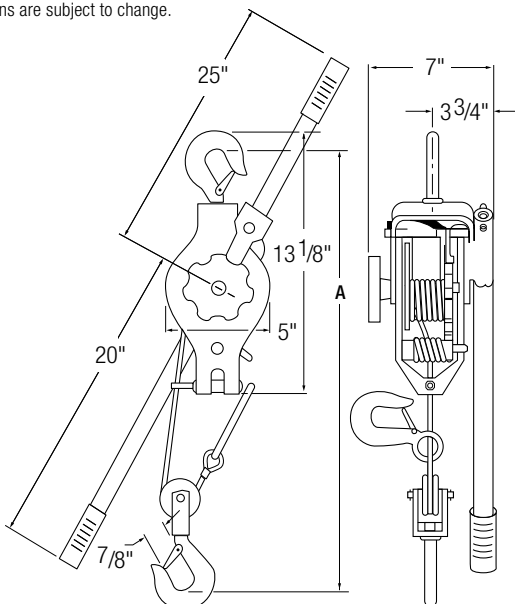

Overload safety handle is designed to bend when an overload is detected. Once the handle begins to bend, any additional force will result in additional bending limiting the hoist from lifting beyond it's capacity.

3/4 – 6 metric ton Line Pull Capacity

Features

Our “top of the line” lever chain hoist. The ultimate in performance, endurance.

Enhanced safety

- Unique, innovative “Torsion-Lok” brake system ensures positive brake engagement.
- Free chain knob with color-coded red/green indicator window shows at a glance if hoist is in “load” or “free chain” position.
- Easy to read instructions are conveniently located on handle, and color coordinated with free chain knob.
- Wide throat, forged alloy steel load hooks have slip resistant barbed tips to better retain slings.
- Patented cast steel chain anchor prevents chain end from being pulled through hoist.

Improved performance

- Simple and convenient single-hand “free chaining” allows smooth, trouble-free operation in vertical or horizontal position.
- 360° rotation handle needs only 15° handle movement to ratchet and position loads, a big plus in tight places.
- Available in standard lifts of 5, 10, 15 and 20 feet.

Rugged construction

- Meets ASME B30.21 and HST-3M standards.
- High-strength, cold-formed, stamped steel construction decreases weight while increasing impact resistance.
- Open frame design for easy cleaning and inspection.
- Grade 100 alloy chain.
- Plated fasteners and springs increase reliability and durability.
- A comfortable slip resistant rubber grip handle - even with a glove.
- Top and bottom hooks rotate 360°. Top hook articulates, for flexibility in hard to reach places.

Options

- Plated load chain provides corrosion resistance.
- Overload slip clutch factory set to slip at 150% of rated capacity.
- Bullard bottom hooks for single fall models only.
- Non-standard lifts.



L5H Series Specifications

Model no.	Capacity		Pull to lift rated load lbs	Net wt of chain per ft of lift lbs	No. of chain falls	Load chain size mm	Ship wt w/5 ft of lift lbs
	metric tons	lbs					
L5H150	3/4	1650	35	.57	1	6.3 x 19.2	15
L5H200	1 ⁽¹⁾	2000	43	.57	1	6.3 x 19.2	16
L5H300	1-1/2	3300	40	.74	1	7.1 x 21.2	21
L5H400	2 ⁽¹⁾	4000	49	.74	1	7.1 x 21.2	22
L5H600	3	6600	73	1.19	1	9.0 x 27.2	34
L5H1200	6	13200	77	2.38	2	9.0 x 27.2	62

Note:

Standard lift 5, 10, 15, and 20 ft.

(1) U.S. tons. 2000 lb rating for the 1 ton and 2 ton models only.

L5H Series Dimensions (in.)

Model no.	A (min)	B	C	D	E
L5H150	12.25	6	5	10.12	1.06
L5H200	12.25	6	5	10.12	1.06
L5H300	13.75	6.63	5.75	14.5	1.34
L5H400	13.75	6.63	5.75	14.5	1.34
L5H600	16.75	7.88	7.13	14.5	1.69
L5H1200	22.25	7.88	9.5	14.5	1.88

Note:

Dimensions are subject to change.

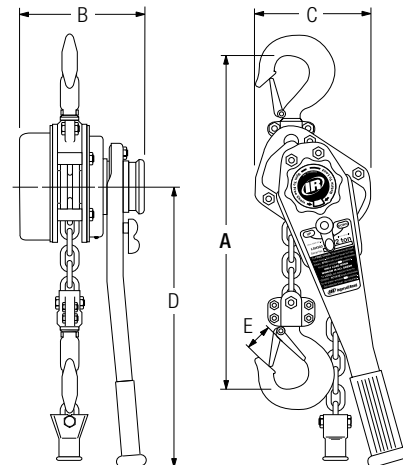

3/4 – 6 metric ton Line Pull Capacity

Features:

A rugged, dependable lever chain hoist with capacities and features that make it ideal for all industrial lifting, pulling and positioning applications.

Enhances safety

- Forged steel alloy load hooks have wide throat openings with slip resistant barbed tips to better retain slings.

Improved performance

- Minimal effort in compact design.
- Heat treated gears and pinions.
- 360° rotation handle needs only 15° handle movement to ratchet and position loads. A big plus in tight places.
- Responsive load control through six pinion gear teeth and a four pocket load sheave.
- Easy free chaining operation.
- Single fall, 3 ton model for increased portability.
- Double reduction gearing for superior spotting characteristics.
- A comfortable slip resistant rubber grip handle - even with a glove.
- Available in standard lifts of 5, 10, 15 and 20 feet.

Rugged construction

- Meets ASME B30.21 and HST-3M design and performance standards.
- High-strength, cold-formed, all stamped steel construction decreases weight while increasing external impact resistance.
- Open frame design for easy cleaning and inspection.
- Grade 100 alloy chain.

Options:

- Plated load chain provides corrosion resistance.
- Aircraft handling, free chain lockout kits.
- Bullard bottom hooks for single fall models only.
- Non-standard lifts.



LV Series Specifications

Model no.	Capacity		Pull to lift rated load lbs	Net wt of chain per ft of lift lbs	No. of chain falls	Load chain size mm	Ship wt w/5 ft of lift lbs
	metric tons	lbs					
LV150	3/4	1650	35	.57	1	6.3 x 19.2	15
LV300	1-1/2	3300	40	.74	1	7.1 x 21.2	21
LV600	3	6600	73	1.19	1	9.0 x 27.2	36
LV1200	6	13200	77	2.38	2	9.0 x 27.2	59

Note:
Standard lift 5, 10, 15, and 20 ft.

LV Series Dimensions (in.)

Model no.	A (min)	B	C	D	E
LV150	11.6	5.8	5.0	9.8	1.1
LV300	12.8	6.4	5.8	14.2	1.3
LV600	15.6	7.6	7.1	14.2	1.7
LV1200	23.2	7.6	9.3	14.2	1.9

Note:
Dimensions are subject to change.

New Option "L" Aircraft Handling, Free Chain Lockout Kits¹

Part no.	Used on models
LV150-KLOCK	All LV150
LV300-KLOCK	All LV300
LV600-KLOCK	All LV600 and LV1200



Note:
(1) Kits replace free chain latch on LV models with a fixed member prohibiting disengagement and the ability to free chain.

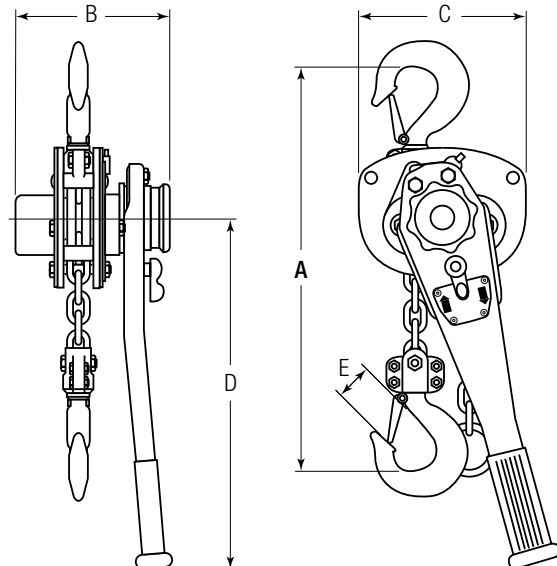

Table of Contents

Ingersoll-Rand Tool and Hoist Division

Ingersoll-Rand offers one of the broadest lines of lifting equipment available. Our hoists are capable of providing solutions in applications throughout the world. From food processing to mining, automotive assembly to construction, IR hoists can be found in the most demanding industries.

The Ingersoll-Rand manual lifting family includes wire and rope pullers, lever chain powered hoists for excellent spotting or fast production needs.

Ingersoll-Rand also offers a wide variety of plain, geared, or powered trolleys as well as tractors to support and mobilize your Ingersoll-Rand hoist.

Solutions to special applications, such as spark hazard or food processing environments can be accommodated by our manufacturing specialists.

Ingersoll-Rand...the *Proven Source* and *Proven Solution* to your lifting equipment needs.

Hoist Limited Warranty

Ingersoll-Rand Company (I-R) warrants its hoists to be free of defects in material and workmanship for one year from the date of purchase. I-R will repair, without cost, any hoist found to be defective, including parts and labor charges, or at its option, will replace such hoists or refund the purchase price. Repairs or replacements are warranted for the remainder of the original warranty period.

If any I-R hoist proves defective within its original one year warranty period, it should be returned to any Authorized Material Handling Distributor, transportation prepaid with proof of purchase or warranty card.

This warranty does not apply to hoists which I-R has determined to have been misused or abused, improperly maintained by the purchaser; or where the malfunction or defect can be attributed to the use of non-genuine I-R parts.

I-R makes no other warranty, and implied warranties including any warranty of merchantability or fitness for a particular purpose are hereby disclaimed. I-R's liability is limited to the purchase price of the hoists and in no event shall I-R be liable for consequential, indirect, or special damages of any nature arising from the sale or use of I-R hoists.

Note:

Some states do not allow limitations on incidental or consequential damages or how long an implied warranty lasts so that the above limitations may not apply to you. This warranty gives you specific legal rights and you may also have other rights which may vary from state to state.



ROUGHNECK™

SILVER SERIES™



PALAIR™ PREMIUM

LO-PRO™

ULTRA-LO™



1/2 – 20 metric ton Lifting Capacity

Features:

Our top of the line manual chain hoist, the VL2 Series exclusive hand chain guide provides smooth, even operation and eliminates jamming when operated away from the load area. Perfect for construction, maintenance, rigging and shipbuilding.

- "Accu-Feed™" hand chain guide articulates for smooth operation and allows for operation from either side away from load being lifted.
- All steel construction for external impact resistance.
- Forged steel alloy load hooks with non-slip design have extra wide throat openings for easy rigging.
- Premium alloy steel grade 100 load chain.
- Thrust bearing bottom block on 3 ton and above helps prevent chain twisting or kinking.
- Chain anchor prevents jamming at the hook's lowest position.
- Needle bearings reduce friction and provide low hand chain pull.
- **Overload Protection** to deter and reduce downtime and repair costs resulting from abuse.
- Available in standard lifts of 10, 15 and 20 feet. Hand chain is 2 feet less than lift.

Options:

- Spark and corrosion resistant models.
- Spark and corrosion resistant load and hand chain.
- Non standard lifts.
- Chain buckets.
- Protective coatings.
- Bullard bottom hooks for single fall models only.

Nylon bushed VL2 hoist hand chain guide. Zinc plated hand chain shown



VL2 Series Specifications

Model no.	Capacity		Pull to lift rated load lbs	Chain o'hauled to lift load 1 ft	Net wt of chain per ft of lift lbs	No. of chain falls	Load chain size mm	Ship wt w/10 ft of lift lbs
	metric tons	lbs						
VL2-005	1/2	1100	55	25	.356	1	5.0 x 15.0	20
VL2-010	1	2200	73	28	.569	1	6.3 x 19.2	26
VL2-015	1 1/2	3300	74	57	.744	1	7.1 x 21.2	45
VL2-020	2	4400	76	73	1.030	1	8.0 x 24.2	50
VL2-030	3	6600	76	112	1.488	2	7.1 x 21.2	52
VL2-050	5	11000	85	181	2.38	2	9.0 x 27.2	94
VL2-080	8	17600	90	272	3.57	3	9.0 x 27.2	150
VL2-100	10	22000	90	362	4.76	4	9.0 x 27.2	188
VL2-150	15	33000	2 x 90	2 x 272	7.14	6	9.0 x 27.2	395
VL2-200	20	44000	2 x 90	2 x 362	9.52	8	9.0 x 27.2	485

Note:
Standard lift 10, 15, and 20 ft.

VL2 Series Dimensions (in.)

Base model	A (min)	B	C	D
VL2-005	12	5 11/16	5	1 1/16
VL2-010	13 5/8	6 3/16	5 13/16	1 3/16
VL2-015	14 5/8	6 7/8	5 13/16	1 11/32
VL2-020	16 3/4	8	7 1/16	1 15/32
VL2-030	19 7/8	8 1/8	5 13/16	1 19/32
VL2-050	25	10 3/8	7 1/16	1 7/8
VL2-080	29 1/8	13 5/8	7 1/16	2 5/8
VL2-100	29 15/16	14 7/16	7 1/16	2 5/8
VL2-150	33 1/2	29 3/8	8 3/16	3 7/16
VL2-200	34 1/4	34 3/8	8 3/16	3 7/16

Note:
Dimensions are subject to change.

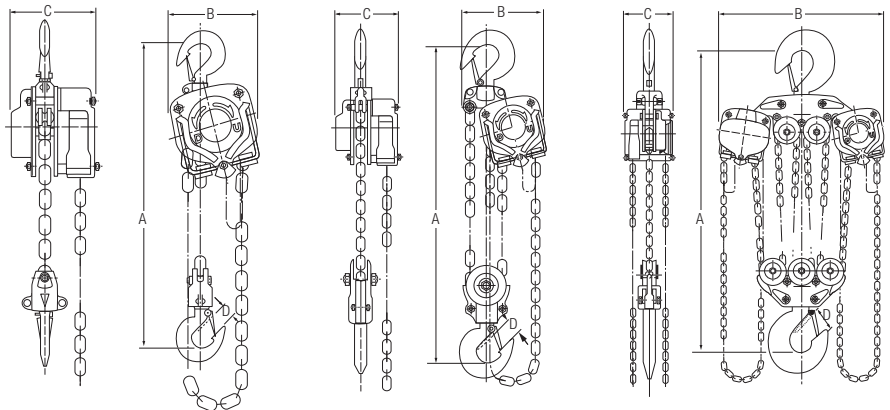

1/2 through 2 tons

3 through 10 tons

15 and 20 tons

Industrial Lifting Equipment

MCH5 “Classic” Series Manual Chain Hoist



1/2 – 5 metric ton Lifting Capacity

Features:

Downscaled version of the VL2 for applications with lower duty cycles. Ideal for maintenance use application.

- Compact design for limited headroom applications.
- High strength steel frame and gear case built to be durable for the rugged needs of construction and maintenance rigging.
- Heat-treated spur gear is efficiently designed to provide smooth load handling and low hand chain pull.
- Open frame design for self-cleaning, quick load sheave inspection and easy hoist maintenance.
- Designed to international standards, non-slip load hooks and top hooks are fitted with hook latches.
- Premium alloy steel grade 100 load chain.
- Standard lifts 10, 15, and 20 feet available from stock.

Options:

- Spark and corrosion resistant load and hand chain.
- Overload protection.
- Chain buckets.
- Bullard bottom hooks for single fall models only.



MCH5 Series Specifications

Model no.	Capacity		Pull to lift rated load lbs	Chain o’hauled to lift load 1 ft	Net wt of chain per ft of lift lbs	No. of chain falls	Load chain size mm	Ship wt w/10 ft of lift lbs
	metric tons	lbs						
MCH5-005	1/2	1100	59	25	.356	1	5.0 x 15.0	20
MCH5-010	1	2200	76	39	.569	1	6.3 x 19.2	26
MCH5-015	1 1/2	3300	78	58	.744	1	7.1 x 21.2	45
MCH5-020	2	4400	80	75	1.03	1	8.0 x 24.2	50
MCH5-030	3	6600	81	116	1.488	2	7.1 x 21.2	52
MCH5-050	5	11000	89	187	2.38	2	9.0 x 27.2	94

Note:
Standard lift 10, 15, and 20 ft.

MCH5 Series Dimensions (in.)

Base model	A (min)	B	C	D
MCH5-005	12	5 ¹¹ / ₁₆	5	1 ¹ / ₁₆
MCH5-010	13 ⁵ / ₈	6 ³ / ₁₆	5 ³ / ₄	1 ³ / ₁₆
MCH5-015	14 ⁵ / ₈	6 ⁷ / ₈	5 ³ / ₄	1 ³ / ₈
MCH5-020	16 ³ / ₄	8	7	1 ⁷ / ₁₆
MCH5-030	19 ⁷ / ₈	8 ¹ / ₈	5 ³ / ₄	1 ¹¹ / ₁₆
MCH5-050	25	10 ³ / ₈	7	1 ⁷ / ₈

Note:
Dimensions are subject to change.

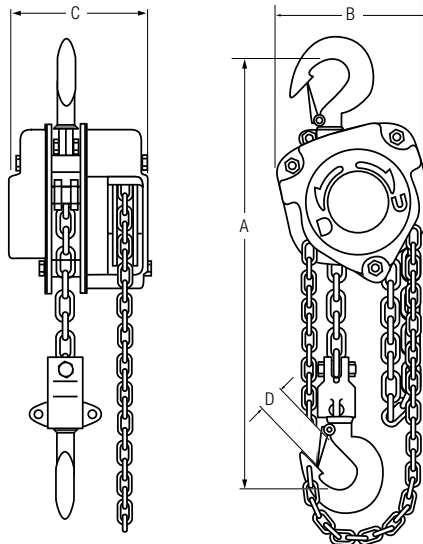

1/2 – 5 metric ton Lifting Capacity

Features:

A NEW design for the year 2000 workplace with safety and performance in mind. Meets or exceeds world specifications including ASME B30.16. A value line product with premium features at a Great Price.

- Overload Protection to deter and reduce downtime and repair costs resulting from abuse.
- All steel, low headroom, light weight construction.
- Self-adjusting disc type double pawl mechanical load brake.
- Hardened roller bearings for maximum efficiency and durability.
- Improved 4 layer finish of nickel, copper, nickel, and chrome complementing our Silver Series lever hoist companion product.
- Ideally suited for the Rental and Construction markets.
- Standard lift (L) is 10 feet, Hand chain drop (D) is 2 feet less than lift (unless specified).

Options:

- Bullard bottom hooks for single fall models only.

SMA Series Specifications

Model no.	Capacity		Pull to lift rated load lbs	Chain o'hailed to lift load 1 ft	Net wt of chain per ft of lift lbs	No. of chain falls	Load chain size mm	Ship wt w/10 ft of lift lbs
	metric tons	lbs						
SMA005	1/2	1100	48	25	.55	1	6.3 x 18	18
SMA010	1	2200	75	39	.55	1	6.3 x 18	26
SMA015	1 1/2	3300	84	58	.80	1	8.0 x 24	39
SMA020	2	4400	81	75	1.10	2	6.3 x 19	35
SMA030	3	6600	90	116	1.60	2	8.0 x 24	55
SMA050	5	11000	97	187	1.40	2	10.0 x 30	86

Note:
Standard lift 10

SMA Series dimensions (in.)

Model	A (min)	B	C	D	E	F	G	J
SMA005	11.6	5.3	.82	.85	.60	2.8	4.2	.59
SMA010	13.0	5.7	1.0	1.1	.78	3.6	5.1	.75
SMA015	16.1	7.6	1.1	1.2	.97	4.1	5.8	.87
SMA020	17.7	5.7	1.2	1.3	1.1	4.5	5.1	.98
SMA030	20.7	7.6	1.4	1.5	1.4	5.1	5.8	1.1
SMA050	24.0	8.3	1.5	1.7	1.7	5.9	6.6	1.3

Note:
Dimensions are subject to change.

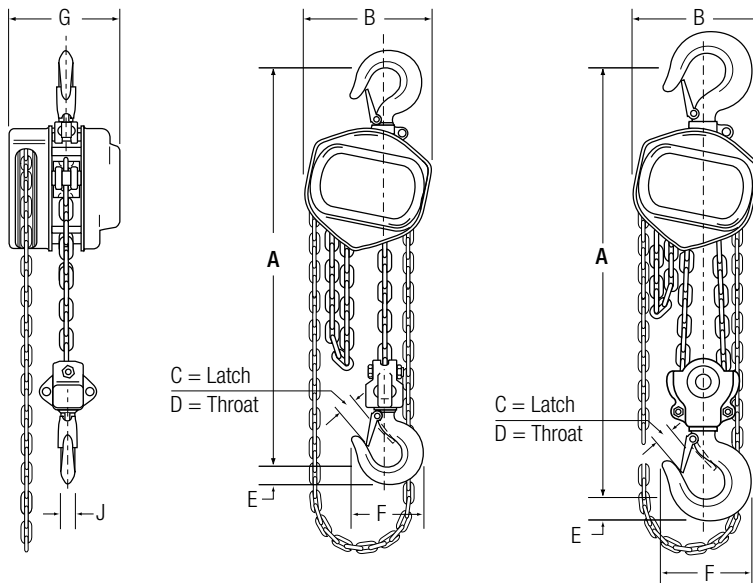

Industrial Lifting Equipment

THV "Lo-Pro" Series Manual Chain Hoist



1/2 – 10 metric ton Lifting Capacity

Features:

Low headroom "Army Style" type trolley hoist

- Utilizes our premium VL2 hoist with a "low profile" trolley.
- All steel construction for external impact resistance.
- Forged steel alloy load hooks with non-slip design have extra wide throat openings for easy rigging.
- Premium grade 100 alloy steel load chain.
- Contour trolley wheel design provides maximum beam contact on flat or tapered beams.
- Thrust bearing bottom block helps prevent chain twisting or kinking.
- Overload Protection to deter and reduce downtime and repair costs resulting from abuse.
- Needle bearings reduce friction and provide low hand chain pull.
- Overload clutch.

Options:

- Spark and corrosion resistant models available.
- Trolley shaft extensions for wider flanges.
- Trolley lugs and rubber bumpers.
- Chain containers.
- Choice of plain or geared trolleys.
- Variable lengths of lift for special requirements.
- Special inquiries invited.
- Bullard bottom hooks for single fall models only.



THV Series Specifications

Model no.	Capacity		Pull to lift rated load lbs	Chain o'hauled to lift load 1 ft	Net wt of chain per ft of lift lbs	No. of chain falls	Load chain size mm	Ship wt w/10 ft of lift lbs in.	Std flange adjustment in.	Shipping wt trolley type lbs	
	metric tons	lbs								Plain	Geared
THV005	1/2	1100	55	25	.95	1	5.0 x 15.0	15	2.5 – 5	35	38
THV010	1	2200	73	39	1.16	1	6.3 x 19.2	29	2.5 – 5	50	54
THV020	2	4400	76	75	1.51	1	8.0 x 24.2	37	3 – 5	90	96
THV030	3	6600	76	116	2.08	2	7.1 x 21.2	44	3 – 5	120	128
THV050	5	11000	85	187	3.00	2	9.0 x 27.2	55	3 – 5	205	255
THV080	8	18000	90	281	4.21	3	9.0 x 27.2	60	4 – 6	385	420
THV100	10	22000	90	375	5.42	4	9.0 x 27.2	60	4 – 6	455	480

Note:

Standard lift 10

Standard hand chain length for hoist and trolley is 2 feet less than lift.

THV Series Dimensions (in.)

Base model	A (min)	C	D	E	F	G	H	I
THV005	10 ⁵ / ₈	10	4 ¹ / ₂	5 ¹ / ₂	3 ³ / ₄	1 ¹ / ₁₆	1 ¹ / ₂	4 ¹ / ₄
THV010	12 ¹¹ / ₁₆	10	4 ¹ / ₂	5 ¹ / ₂	7 ⁷ / ₈	1 ¹ / ₈	1 ¹ / ₂	4 ¹ / ₄
THV020	15 ³ / ₁₆	12 ⁵ / ₈	5 ³ / ₈	7 ¹ / ₈	1 ³ / ₈	1 ¹ / ₂	1 ¹ / ₈	5
THV030	17 ³ / ₈	14	6 ¹ / ₄	7 ⁷ / ₈	1 ¹ / ₂	1 ⁵ / ₈	1 ¹ / ₂	5 ³ / ₄
THV050	21 ¹ / ₂	17 ¹ / ₂	7	10 ¹ / ₂	1 ⁷ / ₈	1 ³ / ₄	1 ⁷ / ₁₆	6 ⁵ / ₈
THV080	26 ³ / ₄	20 ¹ / ₂	7 ³ / ₄	9 ⁷ / ₈	2 ⁷ / ₈	2 ¹ / ₂	1 ³ / ₁₆	7 ³ / ₈
THV100	27 ⁵ / ₈	20 ¹ / ₂	7 ³ / ₄	9 ⁷ / ₈	2 ⁷ / ₈	2 ¹ / ₂	1 ³ / ₁₆	7 ³ / ₈

THV Series Dimensions (in.) continued

Base model	J	K	L	N	P	Q	R	T ¹
THV005	2 ³ / ₄	b + 1 ⁷ / ₈	1 ³ / ₈	b - 1 ⁷ / ₈	2 ³ / ₄	6 ¹ / ₄	1 ² / ₂	11 ⁵ / ₈
THV010	2 ³ / ₄	b + 1 ⁷ / ₈	1 ³ / ₈	b - 1 ⁷ / ₈	2 ³ / ₄	6 ³ / ₈	5 ⁵ / ₈	11 ⁵ / ₈
THV020	3 ³ / ₈	b + 2	1 ¹ / ₂	b - 2 ¹ / ₈	3 ¹ / ₂	7 ¹ / ₄	7 ⁷ / ₈	11 ⁵ / ₈
THV030	4	b + 2 ¹ / ₈	1 ⁵ / ₈	b - 2 ³ / ₈	3 ¹ / ₈	6 ³ / ₄	1 ¹ / ₈	12
THV050	4 ³ / ₄	b + 2 ³ / ₄	2 ¹ / ₈	b - 2 ⁷ / ₈	3 ¹ / ₂	7 ¹ / ₂	1 ³ / ₈	14 ¹ / ₂
THV080	6 ¹ / ₈	b + 3 ¹ / ₄	2 ³ / ₈	b - 3 ¹ / ₂	4	8 ¹ / ₄	2 ¹ / ₈	18 ³ / ₄
THV100	6 ¹ / ₈	b + 3 ¹ / ₄	2 ³ / ₈	b - 3 ¹ / ₂	4	8 ¹ / ₄	2 ¹ / ₈	18 ³ / ₄

Note:

(1) Applicable for geared trolleys only.

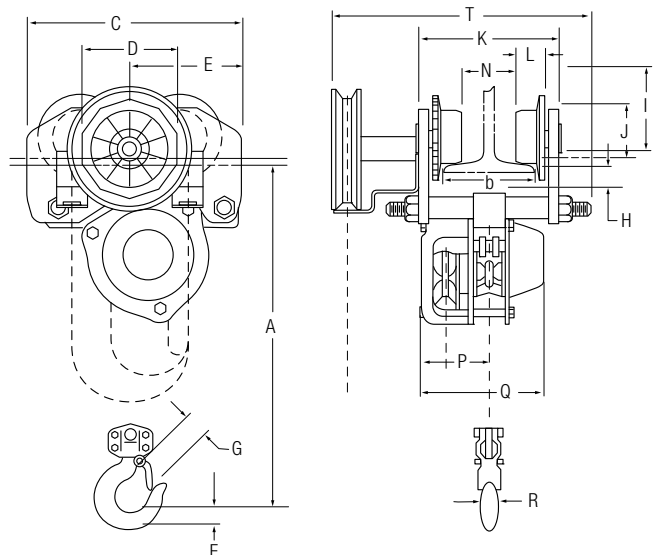

1/4 – 25 US Ton Lifting Capacity

Features:

Ingersoll-Rand’s ULM2 and ULM2S have been designed to offer our lowest headroom possible, maximizing lifting capacities for areas with height restrictions.

- All steel construction for external impact resistance.
- Forged steel load hooks.
- Chill-hardened, machine tread trolley wheels with 2 precision bearings per wheel.
- Swivel trolleys available to travel extremely tight radius, (as tight as 21 feet) for track without sacrificing headroom for capacities up to 6 ton.
- Custom built for easy installation.
- Low headroom capacities available from 1/4 through 25 ton.
- 2 roller thrust bearings used in trolley capacities 3 tons and larger for longer life and reliability.
- Corrosion resistant zinc plated hand chain.
- Designed and built to ANSI B30.16.

Options:

- Stainless steel and bronze parts available for spark resistant features.
- Corrosion resistant finish.
- Overload clutch for all capacities.
- Chain container for all capacities and all lifts up to 50 feet.
- Track clamps.
- Hand wheel extensions.
- Zinc plated load chain.

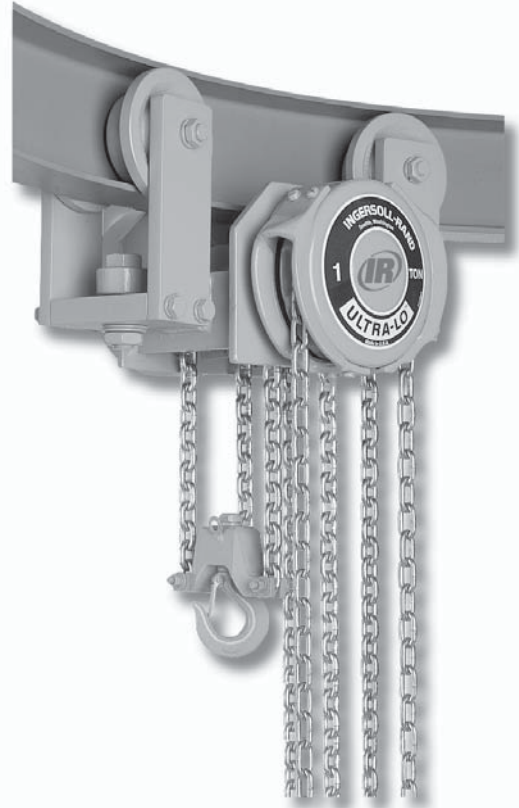

ULM2 and ULM2S Series Specifications

Model no.	Capacity		Pull to lift rated load lbs	Chain o’hauled to lift load 1 ft	No. of chain falls per side	Load chain size mm	Straight track flange adj in.	Min curve radius in.	Max width for min curve radius in.	Ship wt trolley type lbs	
	US tons	lbs								Plain	Geared
ULM2 Series											
ULM2-015	1½	3000	41	87	1 x 1	7.14	3.33-8.00	78	–	207	230
ULM2-020	2	4000	54	87	1 x 1	7.14	3.33-8.00	78	–	210	233
ULM2-030	3	6000	42	176	2 x 2	7.14	4.00-8.00	78	–	305	355
ULM2-040	4	8000	56	176	2 x 2	7.14	4.00-8.00	90	–	308	340
ULM2-050	5	10000	79	165	1 x 1	13.49	4.63-8.00	102	–	574	633
ULM2-060	6	12000	94	165	1 x 1	13.49	4.63-8.00	102	–	574	633
ULM2-080	8	16000	64	355	2 x 2	9.53	4.63-8.00	114	–	650	773
ULM2-100	10	20000	87	330	2 x 2	13.49	5.00-8.00	–	–	1022	1105
ULM2-120	12	24000	104	330	2 x 2	13.49	5.00-8.00	–	–	1022	1105
ULM2-160	16	22000	68	710	4 x 2	9.53	5.00-8.00	–	–	1600	1681
ULM2-200	20	40000	87	732	4 x 2	13.49	6.00-8.00	–	–	1950	2110
ULM2-240	24	48000	104	732	4 x 2	13.49	6.00-8.00	–	–	1950	2110
ULM2-250	25	50000	104	732	4 x 2	13.49	6.00-8.00	–	–	1950	2110
ULM2S Series											
ULM2S003	¼	500	17	33	1 x 1	7.14	3.00-5.38	21	3.38	110	127
ULM2S005	½	1000	35	33	1 x 1	7.14	3.00-5.38	21	3.38	127	144
ULM2S010	1	2000	70	33	1 x 1	7.14	3.00-5.38	21	3.38	127	144
ULM2S015	1½	3000	57	66	2 x 2	7.14	3.31-6.00	30	4.00	245	267
ULM2S020	2	4000	76	66	2 x 2	7.14	3.31-6.00	30	4.00	251	270
ULM2S030	3	6000	42	170	2 x 2	7.14	4.00-6.00	42	5.88	345	375
ULM2S040	4	8000	58	170	2 x 2	7.14	4.00-6.00	48	5.88	350	380
ULM2S050	5	10000	73	170	2 x 2	7.14	4.63-8.00	48	7.88	466	496
ULM2S060	6	12000	90	170	2 x 2	7.14	4.63-8.00	48	7.88	466	496

Note:

Standard lift is 8 ft.

Maximum flange thickness for ULM2S003–030 is 1/2 in., ULM2S040–060 is 5/8 in.

Industrial Lifting Equipment

ULM2/S "Ultra-Lo" Series Manual Chain Hoist



1/4 – 25 US Ton Lifting Capacity

ULM2 and ULM2S Beam Flange Chart (in.)

Plain and geared trolleys for straight and curved track

	Capacity US Tons	Fits flange width for straight track	Max flange width for min curve radius	flange thickness for radius min	max
ULM2 Series					
ULM2-015, ULM2-020	1 1/2, 2	3 3/8 – 8	–	–	–
ULM2-030, ULM2-040	3, 4	4 – 8	–	–	–
ULM2-050, ULM2-060, ULM2-080	5, 6, 8	4 5/8 – 8	–	–	–
ULM2-100, ULM2-120	10, 12	5 – 8	–	–	–
ULM2-160, ULM2-200	16, 20	5 1/2 – 8	–	–	–
ULM2-240, ULM2-250	24, 25	6 – 8	–	–	–
ULM2S Series					
ULM2S003, ULM2S005, ULM2S010	1/4, 1/2, 1	3 – 5 3/8	3 3/8	21	1/2
ULM2S015, ULM2S020	1 1/2, 2	3 3/8 – 6	4	30	1/2
ULM2S030, ULM2S040	3, 4	4 – 6	5 7/8	42	5/8
ULM2S050, ULM2S060	5, 6	4 5/8 – 8	7 7/8	48	7/8

Note:

Contact Technical Sales for wider beam flange applications.

ULM2 Series Dimensions (in.)

Capacity U.S. Tons	A (min)	B	C	D	E	E1	F	G	H	J	L	M	N ¹	P ²	R	S
1 1/2 & 2	6 1/4	20 3/8	10 3/16	10 3/16	5 1/8	5 1/8	8 3/4	8 1/4	5/8	1 1/8	1 1/8	4 1/2	1/2	6" I@ 12.5#	13 1/16	6
3	7 3/8	20 3/8	10 3/16	10 3/16	6 1/2	6 5/8	10 5/8	10 5/8	9/16	1 11/32	1 11/32	6 3/8	1/2	8" I@ 18.4#	13 1/16	8
4	8	20 3/8	10 3/16	10 3/16	6 1/2	6 5/8	10 5/8	10 5/8	9/16	1 11/16	1 11/32	6 3/8	1/2	8" I@ 18.4#	13 1/16	8
5 & 6	8 3/4	26 1/4	13 1/8	13 1/8	7 3/8	7 3/8	12	12	29/32	1 11/16	1 11/32	7 3/16	9/16	10" I@ 25.4#	16 1/2	9
8	11	26 1/4	13 1/8	13 1/8	8 3/8	8 3/8	14	13 1/2	9/16	2 1/16	1 11/16	8 1/4	9/16	10" I@ 25.4#	16 1/2	10
10 & 12	11 1/2	26 1/4	13 1/8	13 1/8	8 1/2	9 3/4	15 5/8	14 3/8	9/16	2 1/4	1 3/4	9 3/4	5/8	12" I@ 31.8#	16 1/2	11 11/16
16	13 3/8	30 3/8	15 3/16	15 3/16	11 7/8	11 7/8	18 5/8	18 5/8	9/16	3	2	11 3/4	3/4	15" I@ 42.9#	18 7/8	13 1/2
20, 24 & 25	17 1/4	30 3/8	15 3/16	15 3/16	12 1/8	12 3/8	19 1/4	19	3/4	3 5/8	2	11 3/4	5/8	18" I@ 54.7#	18 7/16	13 1/2

Note:

(1) At under beam roller

(2) Minimum standard I-Beam for proper wheel running clearance. Contact factory for smaller beams. Customer must verify their beam is adequate for applied loads.

ULM2S series dimensions (in.)

Capacity U.S. Tons	A (min)	B	C	D	E	F	G ¹	G ²	H	I	J	K ²	L ²	M	N	O
1/4 thru 1	6 1/4	2	6 9/16	6 9/16	3 3/4	5	2 3/16	1 1/8	3 1/32	4 11/16	3 3/4	7 1/4	6 1/2	2 1/2	1 3/8	2 15/16
1 1/2 & 2	6 3/4	2 3/16	9 1/8	9 1/8	4 1/2	6	5/8	5/8	1 1/8	7 3/16	6 1/4	11 3/8	7 5/8	3	3	1 7/8
3	8 3/4	2 9/16	9 7/8	9 7/8	6 3/8	8	15/16	15/16	1 11/32	8 1/8	6 1/8	11 9/16	7 11/16	4	3	1 7/8
4	9 1/4	2 9/16	9 7/8	9 7/8	6 3/8	8	15/16	15/16	1 11/16	8 1/8	6 1/8	11 9/16	7 11/16	4	3	3 7/16
5 & 6	9 5/16	2 13/16	10 1/8	10 1/8	7 3/16	9	7/8	7/8	1 11/16	8 1/2	6 15/16	11 9/16	8 13/16	4 1/2	3	3 7/8

Note:

(1) Plain

(2) Geared

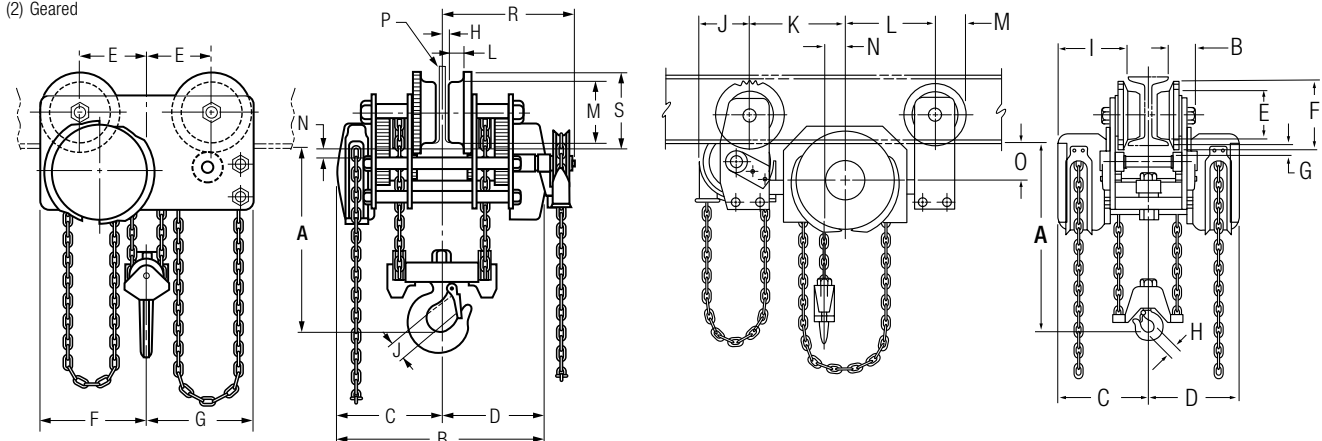

1/8 – 5 metric ton Lifting Capacity

Features:

1. Eyebolt suspension:

An eyebolt suspension is standard with motorized and plain trolleys. Unlike rigid suspensions, the eyebolt suspension allows the hoist to pivot and align itself to the direction of load pull, reducing stress and wear. (Hook suspension can be substituted).



2. Overload clutch for asset protection:

The overload clutch is factory set to limit Quantum from lifting loads in excess of 150% of rated hoisting capacity.



3. Gear case:

Smooth and compact design with a helical/spur gear combination providing “grab free” movement and quiet, reliable operation. Optimum lubrication – Gears are lubricated with a semiliquid grease instead of oil, which is less likely to leak, eliminates oil level checks and clings to the gears even after long idle periods. Quantum will even work upside down.

4. Chain guide and wheel:

A “floating” chain guide precisely feeds chain onto a machined-matched five-pocket chain wheel. This system insures smooth, jam resistant operation, and extends load chain, and chain wheel life.



5. Optimized load chain:

Quantum load chain is precision formed from alloy steel, case hardened and zinc plated. The plating is an IR proprietary process, which resists corrosion better than any standard plating offered for load chain.

Controlled elongation: Quantum chain is engineered to elongate a minimum of 10%.

This ability to stretch reduces the possibility of catastrophic failure under sudden loading.



6. Motors:

High starting torque – Quantum motors are a totally enclosed non-ventilated (TENV) squirrel cage design. The H4 duty classification of the three phase models allows for 300 starts and 30 minutes “on time” per hour. Class F insulation allows a total thermal rating of 145° C at a 1.0 service factor, instead of the more common Class B insulation of 120° C. Quantum motors can take the heat!

Phased to your needs – Single phase motors are available as 115 or 230 volt. Because single-phase motors are subject to low voltages that create higher motor temperatures, these Quantum hoists are equipped with “klixons,” bimetal heat switches that prevent motor burnout. *Three phase motors* – are available in 230, 380, 460, and 575 volts, single and dual speeds. The 230/460 volt, single speed motors are field reconnectable.

Dual speed motors – feature 4, 5, or 6 to 1 high to low speed ratios instead of the typical 3 to 1 ratios. The advantages are unsurpassed load control, reduced cycle time and improved productivity. The overload clutch and Class F insulation eliminate the cost of “klixons.”

7. Brake:

Metal discs stack up against wear – Quantum has a state-of-the-art AC motor brake employing all-steel discs. Multiple stacking significantly increases braking surface area, reducing wear and extending life. This system eliminates the breakage common with fiber discs and the heavier steel springs and DC solenoids they require. Quantum brake discs are guaranteed for the life of the hoist.



8. Electrical controls:

Safety-first pendent – Quantum’s safety-first pendent control handles are comfortable and fit securely in the operator’s hand. Each low voltage (42 volt) control handle integrates a large, red emergency stop button. Operating buttons are clearly marked with high contrast arrows, feature soft push action, and are horizontally aligned for easier operation.

Emergency shut-off – Activated from the pendent handle, the mainline contactor disconnects the power to the hoist and trolley motor providing “shut-off protection” in an emergency situation.

Easy accessibility – Quantum enclosures are weatherproof, NEMA 3R rated. The removal of just four fasteners (slot-head on the electrical parts cover and allen-head on the mechanical parts cover) allows access to components. Since electrical and mechanical components can be accessed separately, service is quick and clean.

9. Limit switches:

Fail-safe limits – Quantum limit levers are recessed in the hoist enclosure. This clean, obstruction-free assembly virtually eliminates accidental activation of switches. Upper and lower switches are activated by the hook and end stop, eliminating time-consuming adjustments.



Industrial Lifting Equipment

Quantum Series Electric Chain Hoist

1/8 – 5 metric ton Lifting Capacity

Design Features:

- UL and C-UL listed (except 380 volt units). Complete unit listed number is 5D48.
- Meets I-R's interpretation of ANSI B30.16 and pertinent European FEM standards.
- Small compact light weight, high tensile strength, die cast aluminum housing.
- NEMA 3R hoist enclosure and NEMA 4X pendant enclosure can be used outdoors.
- Universal tread trolley wheels fit tapered or flat flange beams.
- Hook, eyebolt, push trolley or motorized trolley suspensions.
- Safety lugs on all trolleys.
- Anti-tip lugs on motorized trolleys.
- Well balanced, modular design.

Options:

- Trolley brake.
- Chain container.
- External strain relief.
- Power cord lengths.
- Geared limits.
- Handy Handle.
- 110 Volt controls.
- Inertia type mechanical load brake.
- Pendant with vertical aligned buttons.
- Pendant with additional 2 or 4 aligned buttons.
- Bullard top and bottom hooks.



Optional geared limit switch

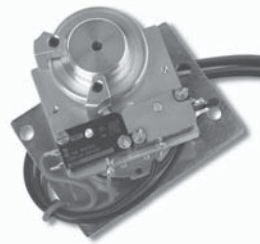

- Inertia type mechanical load brake. This option specifies a bolt-on inertia mechanical load brake. The inertia type brake responds to overspeed of the load. It's similar in function to many safety devices including elevator safety brakes and automotive seat belts. If a dual brake is required this option is ideal as it does not reduce duty cycle, from heat created by drag, or require adjustment to compensate for wear.

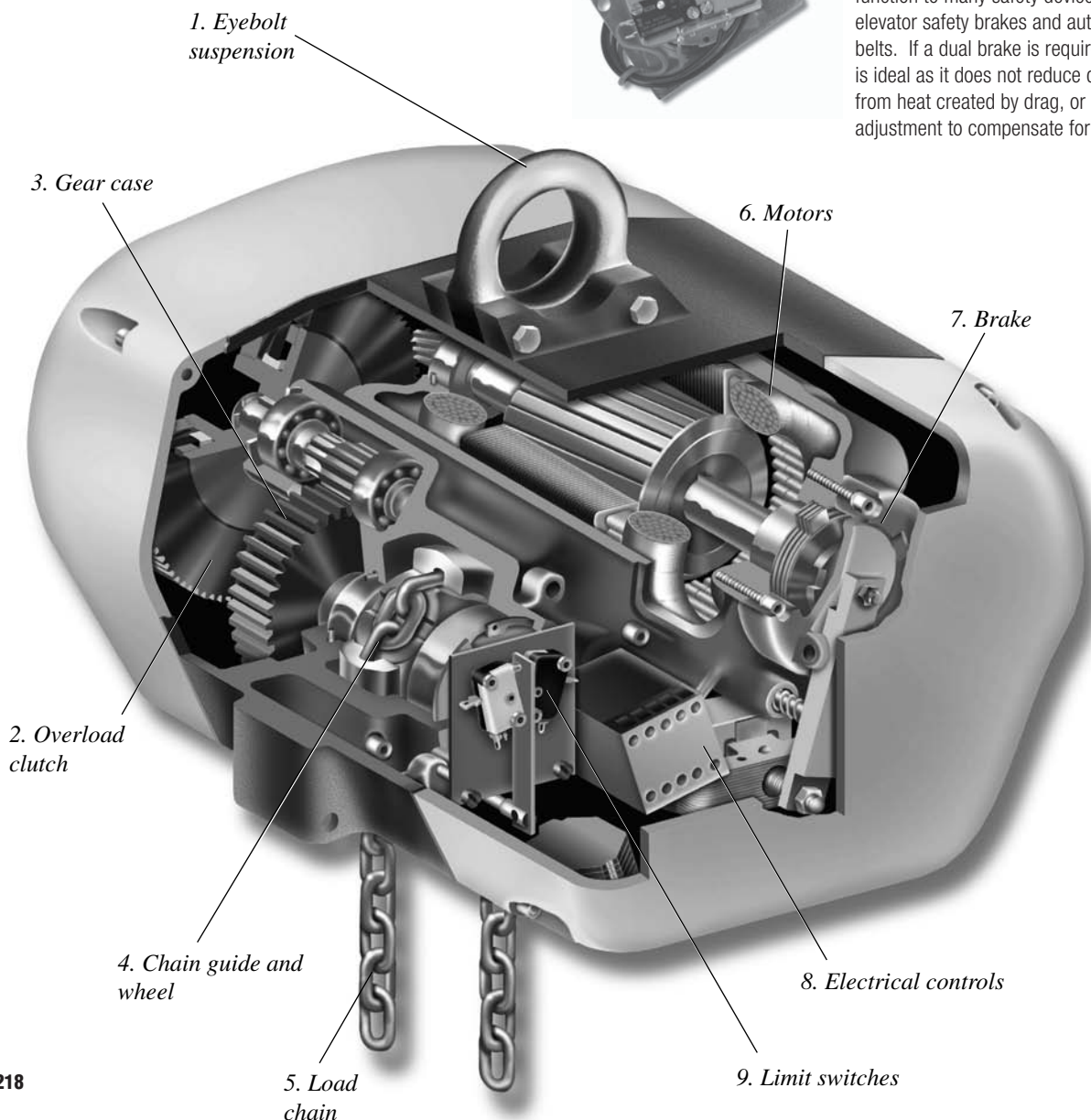

1/8 – 5 metric ton Lifting Capacity

Quantum Series specifications																	
Base model	Cap. metric tons	Chain falls	Lift spd fpm	Motor hp used	Amperage						Chain & pendent wt (lbs/ft)	Eye & hook wt (lbs)	Curve radius min	S beam min	Push trolley, PT Series		Wt ⁽¹⁾ lbs
					Single phase 115V	230V	230V	Three phase 460V	575V	380V					Flange Width (in.) A	D	
Single Phase (Single Speed)																	
Q50-1NS12	1/8	1	36	0.3	13	6.7	n/a	n/a	n/a	n/a	.24	49	36	4	2 ¹¹ / ₁₆ – 4 ¹¹ / ₁₆	2 ¹¹ / ₁₆ – 8 ¹ / ₁₆	69
Q50-1NS25	1/4	1	36	0.7	13	6.7	n/a	n/a	n/a	n/a	.37	54	36	4	2 ¹¹ / ₁₆ – 4 ¹¹ / ₁₆	2 ¹¹ / ₁₆ – 8 ¹ / ₁₆	74
Q50-1NS50	1/2	1	18	0.7	13	6.7	n/a	n/a	n/a	n/a	.37	54	36	4	2 ¹¹ / ₁₆ – 4 ¹¹ / ₁₆	2 ¹¹ / ₁₆ – 8 ¹ / ₁₆	74
Q100-1NS50	1/2	1	32	1.2	16	8.0	n/a	n/a	n/a	n/a	.70	104	36	4	2 ¹¹ / ₁₆ – 4 ¹¹ / ₁₆	2 ¹¹ / ₁₆ – 8 ¹ / ₁₆	124
Q50-2NS100	1	2	9	0.7	13	6.7	n/a	n/a	n/a	n/a	.74	60	36	5	3 – 5 ¹ / ₄	3 – 8 ¹ / ₁₆	80
Q100-2NS100	1	2	16	1.2	16	8.0	n/a	n/a	n/a	n/a	1.40	123	36	5	3 – 5 ¹ / ₄	3 – 8 ¹ / ₁₆	178
Q200-1NS100	1	1	16	1.2	16	8.0	n/a	n/a	n/a	n/a	1.18	139	36	5	3 – 5 ¹ / ₄	3 – 8 ¹ / ₁₆	211
Q200-2NS200	2	2	8	1.2	16	8.0	n/a	n/a	n/a	n/a	2.36	167	48	6	3 ¹¹ / ₃₂ – 6	3 ¹¹ / ₃₂ – 8 ¹ / ₁₆	222
Q500-1NS200	2	1	12	1.8	n/a	10.0	n/a	n/a	n/a	n/a	1.52	157	48	6	3 ¹¹ / ₃₂ – 6	3 ¹¹ / ₃₂ – 8 ¹ / ₁₆	212
Q500-2NS300	3	2	6.2	1.4	n/a	10.0	n/a	n/a	n/a	n/a	3.04	173	60	8	4 – 6 ¹ / ₄	4 – 8 ¹ / ₁₆	279
Q500-2NS400	4	2	6.2	1.9	n/a	10.0	n/a	n/a	n/a	n/a	3.04	173	60	10	4 ²¹ / ₃₂ – 7 ¹ / ₄	4 ²¹ / ₃₂ – 8 ¹ / ₁₆	279
Three Phase (Single Speed)																	
Q50-1NS12	1/8	1	36	0.3	n/a	n/a	2.4	1.2	1.0	1.2	.24	49	36	4	2 ¹¹ / ₁₆ – 4 ¹¹ / ₁₆	2 ¹¹ / ₁₆ – 8 ¹ / ₁₆	69
Q50-1NS25	1/4	1	36	0.6	n/a	n/a	2.4	1.2	1.0	1.2	.24	49	36	4	2 ¹¹ / ₁₆ – 4 ¹¹ / ₁₆	2 ¹¹ / ₁₆ – 8 ¹ / ₁₆	69
Q50-1HS25	1/4	1	64	1.2	n/a	n/a	4.2	2.1	1.7	2.1	.37	54	36	4	2 ¹¹ / ₁₆ – 4 ¹¹ / ₁₆	2 ¹¹ / ₁₆ – 8 ¹ / ₁₆	74
Q50-1NS50	1/2	1	36	1.4	n/a	n/a	3.8	1.9	1.6	1.6	.37	54	36	4	2 ¹¹ / ₁₆ – 4 ¹¹ / ₁₆	2 ¹¹ / ₁₆ – 8 ¹ / ₁₆	74
Q100-1HS50	1/2	1	64	2.4	n/a	n/a	11.0	5.7	4.6	5.0	.70	100	36	4	2 ¹¹ / ₁₆ – 4 ¹¹ / ₁₆	2 ¹¹ / ₁₆ – 8 ¹ / ₁₆	120
Q50-2NS100	1	2	18	1.4	n/a	n/a	3.8	1.9	1.6	1.9	.74	60	36	5	3 – 5 ¹ / ₄	3 – 8 ¹ / ₁₆	90
Q100-1NS100	1	1	32	2.4	n/a	n/a	7.6	3.8	3.1	3.3	.70	100	36	5	3 – 5 ¹ / ₄	3 – 8 ¹ / ₁₆	130
Q100-2NS200	2	2	16	2.4	n/a	n/a	7.6	3.8	3.1	3.3	1.40	116	48	6	3 ¹¹ / ₃₂ – 6	3 ¹¹ / ₃₂ – 8 ¹ / ₁₆	171
Q300-1NS200	2	1	32	4.8	n/a	n/a	16.0	7.8	6.3	6.8	1.18	149	48	6	3 ¹¹ / ₃₂ – 6	3 ¹¹ / ₃₂ – 8 ¹ / ₁₆	204
Q200-2NS300	3	2	16	3.6	n/a	n/a	12.0	6.0	4.8	6.0	2.36	161	60	8	4 – 6 ¹ / ₄	4 – 8 ¹ / ₁₆	236
Q300-2NS400	4	2	16	4.8	n/a	n/a	16.0	7.8	6.3	6.8	3.04	173	60	10	4 ²¹ / ₃₂ – 7 ¹ / ₄	4 ²¹ / ₃₂ – 8 ¹ / ₁₆	279
Q500-2NS500	5	2	12.5	4.7	n/a	n/a	17.0	8.4	6.8	7.1	3.04	173	60	10	4 ²¹ / ₃₂ – 7 ¹ / ₄	4 ²¹ / ₃₂ – 8 ¹ / ₁₆	279
Three Phase (Dual Speed)																	
Q50-1ND12	1/8	1	36/6	0.3	n/a	n/a	3.6	1.8	1.5	1.8	.24	51	36	4	2 ¹¹ / ₁₆ – 4 ¹¹ / ₁₆	2 ¹¹ / ₁₆ – 8 ¹ / ₁₆	71
Q50-1ND25	1/4	1	36/6	0.6	n/a	n/a	3.6	1.8	1.5	1.6	.24	51	36	4	2 ¹¹ / ₁₆ – 4 ¹¹ / ₁₆	2 ¹¹ / ₁₆ – 8 ¹ / ₁₆	76
Q50-1HD25	1/4	1	50/8	1.2	n/a	n/a	4.4	2.2	1.8	2.2	.37	56	36	4	2 ¹¹ / ₁₆ – 4 ¹¹ / ₁₆	2 ¹¹ / ₁₆ – 8 ¹ / ₁₆	78
Q50-1ND50	1/2	1	36/6	1.4	n/a	n/a	4.4	2.2	1.8	2.1	.37	56	36	4	2 ¹¹ / ₁₆ – 4 ¹¹ / ₁₆	2 ¹¹ / ₁₆ – 8 ¹ / ₁₆	76
Q100-1HD50	1/2	1	64/16	2.4	n/a	n/a	9.8	4.9	4.0	4.9	.70	108	36	4	2 ¹¹ / ₁₆ – 4 ¹¹ / ₁₆	2 ¹¹ / ₁₆ – 8 ¹ / ₁₆	128
Q50-2ND100	1	2	18/3	1.4	n/a	n/a	4.4	2.2	1.8	2.1	.74	62	36	5	3 – 5 ¹ / ₄	3 – 8 ¹ / ₁₆	92
Q100-1ND100	1	1	32/8	2.4	n/a	n/a	8.0	4.0	3.2	3.5	.70	108	36	5	3 – 5 ¹ / ₄	3 – 8 ¹ / ₁₆	138
Q100-2ND200	2	2	16/4	2.4	n/a	n/a	8.0	4.0	3.2	3.5	1.40	125	48	6	3 ¹¹ / ₃₂ – 6	3 ¹¹ / ₃₂ – 8 ¹ / ₁₆	180
Q300-1ND200	2	1	32/8	4.8	n/a	n/a	16.0	7.8	6.3	6.8	1.18	156	48	6	3 ¹¹ / ₃₂ – 6	3 ¹¹ / ₃₂ – 8 ¹ / ₁₆	211
Q200-2ND300	3	2	16/3	3.6	n/a	n/a	12.0	6.0	4.8	6.0	2.36	165	60	8	4 – 6 ¹ / ₄	4 – 8 ¹ / ₁₆	240
Q300-2ND400	4	2	16/4	4.8	n/a	n/a	16.0	7.8	6.3	6.8	3.04	178	60	10	4 ²¹ / ₃₂ – 7 ¹ / ₄	4 ²¹ / ₃₂ – 8 ¹ / ₁₆	284
Q500-2ND500	5	2	12.5/3	4.7	n/a	n/a	17.0	8.4	6.8	7.1	3.04	178	60	10	4 ²¹ / ₃₂ – 7 ¹ / ₄	4 ²¹ / ₃₂ – 8 ¹ / ₁₆	284

Notes:

Multiply speeds shown by .83 for 380V / 50 Hz units

(1) 10 foot lift capacity only.



Eyebolt and Hook suspension



Motorized Trolley Suspension

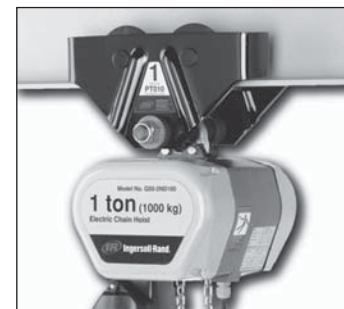

PT Series Plain Trolley with Hook Suspension

Industrial Lifting Equipment

Quantum Series Electric Chain Hoist



1/8 – 5 metric ton Lifting Capacity

Quantum Series Motorized Trolley Specifications – M1, M3 and M4

Base Model	Capacity metric tons	Lifting speed fpm			Motor hp	3 Phase Amperage				S beam hght min in.	Min curve radius in.	Flange width (in.)				Wt ⁽¹⁾ lbs
		M1	M2	M4		230V	460V	575V	380V			A	B	C	D	
Three Phase (Single Speed)																
Q50-1NS12	1/8	39	39	63	.03	1.5	0.75	0.85	0.6	4	48	1 ³¹ / ₃₂ - 3 ⁷ / ₈	3 ¹⁵ / ₁₆ - 5 ⁷ / ₈	5 ²⁹ / ₃₂ - 7 ²⁷ / ₃₂	7 ⁷ / ₈ - 9 ⁷ / ₁₆	109
Q50-1NS25	1/4	39	39	63	.03	1.5	0.75	0.85	0.6	4	48	1 ³¹ / ₃₂ - 3 ⁷ / ₈	3 ¹⁵ / ₁₆ - 5 ⁷ / ₈	5 ²⁹ / ₃₂ - 7 ²⁷ / ₃₂	7 ⁷ / ₈ - 9 ⁷ / ₁₆	109
Q50-1HS25	1/4	39	39	63	.03	1.5	0.75	0.85	0.6	4	48	1 ³¹ / ₃₂ - 3 ⁷ / ₈	3 ¹⁵ / ₁₆ - 5 ⁷ / ₈	5 ²⁹ / ₃₂ - 7 ²⁷ / ₃₂	7 ⁷ / ₈ - 9 ⁷ / ₁₆	114
Q50-1NS50	1/2	39	39	63	.03	1.5	0.75	0.85	0.6	4	48	1 ³¹ / ₃₂ - 3 ⁷ / ₈	3 ¹⁵ / ₁₆ - 5 ⁷ / ₈	5 ²⁹ / ₃₂ - 7 ²⁷ / ₃₂	7 ⁷ / ₈ - 9 ⁷ / ₁₆	114
Q100-1HS50	1/2	39	39	63	.03	1.5	0.75	0.85	0.6	4	48	3 - 5 ¹⁵ / ₃₂	5 ¹ / ₂ - 7 ⁵³ / ₆₄	7 ⁷ / ₈ - 10 ³ / ₁₆	10 ¹ / ₂ - 12 ⁵ / ₈	174
Q50-2NS100	1	39	39	63	.03	1.5	0.75	0.85	0.6	4	48	1 ³¹ / ₃₂ - 3 ⁷ / ₈	3 ¹⁵ / ₁₆ - 5 ⁷ / ₈	5 ²⁹ / ₃₂ - 7 ²⁷ / ₃₂	7 ⁷ / ₈ - 9 ⁷ / ₁₆	120
Q100-1NS100	1	39	39	63	.03	1.5	0.75	0.85	0.6	6	60	3 - 5 ¹⁵ / ₃₂	5 ¹ / ₂ - 7 ⁵³ / ₆₄	7 ⁷ / ₈ - 10 ³ / ₁₆	10 ¹ / ₂ - 12 ⁵ / ₈	174
Q100-2NS200	2	39	39	63	.03	1.5	0.75	0.85	0.6	6	60	3 - 5 ¹⁵ / ₃₂	5 ¹ / ₂ - 7 ⁵³ / ₆₄	7 ⁷ / ₈ - 10 ³ / ₁₆	10 ¹ / ₂ - 12 ⁵ / ₈	190
Q300-1NS200	2	39	39	63	.03	1.5	0.75	0.85	0.6	10	72	2 ³ / ₁₆ - 4 ¹¹ / ₁₆	4 ²³ / ₃₂ - 7 ¹ / ₁₆	7 ³ / ₃₂ - 9 ¹³ / ₃₂	9 ⁷ / ₁₆ - 11 ¹³ / ₁₆	263
Q200-2NS300	3	39	39	63	.03	1.5	0.75	0.85	0.6	10	72	2 ³ / ₁₆ - 4 ¹¹ / ₁₆	4 ²³ / ₃₂ - 7 ¹ / ₁₆	7 ³ / ₃₂ - 9 ¹³ / ₃₂	9 ⁷ / ₁₆ - 11 ¹³ / ₁₆	281
Q300-2NS400	4	39	39	63	.03	1.5	0.75	0.85	0.6	10	72	2 ³ / ₁₆ - 4 ¹¹ / ₁₆	4 ²³ / ₃₂ - 7 ¹ / ₁₆	7 ³ / ₃₂ - 9 ¹³ / ₃₂	9 ⁷ / ₁₆ - 11 ¹³ / ₁₆	287
Q500-2NS500	5	39	39	63	.04	3.0	1.5	1.7	1.2	10	72	2 ³ / ₁₆ - 4 ¹¹ / ₁₆	4 ²³ / ₃₂ - 7 ¹ / ₁₆	7 ³ / ₃₂ - 9 ¹³ / ₃₂	9 ⁷ / ₁₆ - 11 ¹³ / ₁₆	287
Three Phase (Dual Speed)																
Q50-1ND12	1/8	39	39/13	63/21	.03	1.5	0.75	0.85	0.6	4	48	1 ³¹ / ₃₂ - 3 ⁷ / ₈	3 ¹⁵ / ₁₆ - 5 ⁷ / ₈	5 ²⁹ / ₃₂ - 7 ²⁷ / ₃₂	7 ⁷ / ₈ - 9 ⁷ / ₁₆	114
Q50-1ND25	1/4	39	39/13	63/21	.03	1.5	0.75	0.85	0.6	4	48	1 ³¹ / ₃₂ - 3 ⁷ / ₈	3 ¹⁵ / ₁₆ - 5 ⁷ / ₈	5 ²⁹ / ₃₂ - 7 ²⁷ / ₃₂	7 ⁷ / ₈ - 9 ⁷ / ₁₆	111
Q50-1HD25	1/4	39	39/13	63/21	.03	1.5	0.75	0.85	0.6	4	48	1 ³¹ / ₃₂ - 3 ⁷ / ₈	3 ¹⁵ / ₁₆ - 5 ⁷ / ₈	5 ²⁹ / ₃₂ - 7 ²⁷ / ₃₂	7 ⁷ / ₈ - 9 ⁷ / ₁₆	116
Q50-1ND50	1/2	39	39/13	63/21	.03	1.5	0.75	0.85	0.6	4	48	1 ³¹ / ₃₂ - 3 ⁷ / ₈	3 ¹⁵ / ₁₆ - 5 ⁷ / ₈	5 ²⁹ / ₃₂ - 7 ²⁷ / ₃₂	7 ⁷ / ₈ - 9 ⁷ / ₁₆	116
Q100-1HD50	1/2	39	39/13	63/21	.03	1.5	0.75	0.85	0.6	4	48	3 - 5 ¹⁵ / ₃₂	5 ¹ / ₂ - 7 ⁵³ / ₆₄	7 ⁷ / ₈ - 10 ³ / ₁₆	10 ¹ / ₂ - 12 ⁵ / ₈	182
Q50-2ND100	1	39	39/13	63/21	.04	1.5	0.75	0.85	0.6	4	48	1 ³¹ / ₃₂ - 3 ⁷ / ₈	3 ¹⁵ / ₁₆ - 5 ⁷ / ₈	5 ²⁹ / ₃₂ - 7 ²⁷ / ₃₂	7 ⁷ / ₈ - 9 ⁷ / ₁₆	122
Q100-1ND100	1	39	39/13	63/21	.04	1.5	0.75	0.85	0.6	6	60	3 - 5 ¹⁵ / ₃₂	5 ¹ / ₂ - 7 ⁵³ / ₆₄	7 ⁷ / ₈ - 10 ³ / ₁₆	10 ¹ / ₂ - 12 ⁵ / ₈	182
Q100-2ND200	2	39	39/13	63/21	.04	1.5	0.75	0.85	0.6	6	60	3 - 5 ¹⁵ / ₃₂	5 ¹ / ₂ - 7 ⁵³ / ₆₄	7 ⁷ / ₈ - 10 ³ / ₁₆	10 ¹ / ₂ - 12 ⁵ / ₈	199
Q300-1ND200	2	39	39/13	63/21	.04	1.5	0.75	0.85	0.6	10	72	2 ³ / ₁₆ - 4 ¹¹ / ₁₆	4 ²³ / ₃₂ - 7 ¹ / ₁₆	7 ³ / ₃₂ - 9 ¹³ / ₃₂	9 ⁷ / ₁₆ - 11 ¹³ / ₁₆	270
Q200-2ND300	3	39	39/13	63/21	.04	1.5	0.75	0.85	0.6	10	72	2 ³ / ₁₆ - 4 ¹¹ / ₁₆	4 ²³ / ₃₂ - 7 ¹ / ₁₆	7 ³ / ₃₂ - 9 ¹³ / ₃₂	9 ⁷ / ₁₆ - 11 ¹³ / ₁₆	285
Q300-2ND400	4	39	39/13	63/21	.04	1.5	0.75	0.85	0.6	10	72	2 ³ / ₁₆ - 4 ¹¹ / ₁₆	4 ²³ / ₃₂ - 7 ¹ / ₁₆	7 ³ / ₃₂ - 9 ¹³ / ₃₂	9 ⁷ / ₁₆ - 11 ¹³ / ₁₆	292
Q500-2ND500	5	39	39/13	63/21	.04	3.0	1.5	1.7	1.2	10	72	2 ³ / ₁₆ - 4 ¹¹ / ₁₆	4 ²³ / ₃₂ - 7 ¹ / ₁₆	7 ³ / ₃₂ - 9 ¹³ / ₃₂	9 ⁷ / ₁₆ - 11 ¹³ / ₁₆	292

Notes:

Multiply speeds shown by .83 for 380V / 50 Hz units

(1) 10 foot lift capacity only.

Quantum Series Handy Handle

Pendent Control

NEW Handy Handle Control:

Ergonomically designed to provide control and operation at the hook as a robotic power extension of the operator’s arm. The load can be positioned and controlled with one hand, freeing the other hand to position the load.

The Handy Handle can be ordered separately as a kit, to convert any 1/8, 1/4 and 1/2 ton single line Quantum hoist, or as an “H” control option on a new hoist. Each Handy Handle is standard with single or dual speed thumb control lever switches and includes the Quantum red stop safety button. A socket connection at the bottom allows the standard hook to be easily replaced by custom end effectors or grabs.

NEW Ergonomic “Charlie” Pendent:

Features horizontal two speed switch button for up and down hoist operations. The pendent is not available with additional switch button functions. Ordered as an option with the hoist or separately. Part number 04557252.

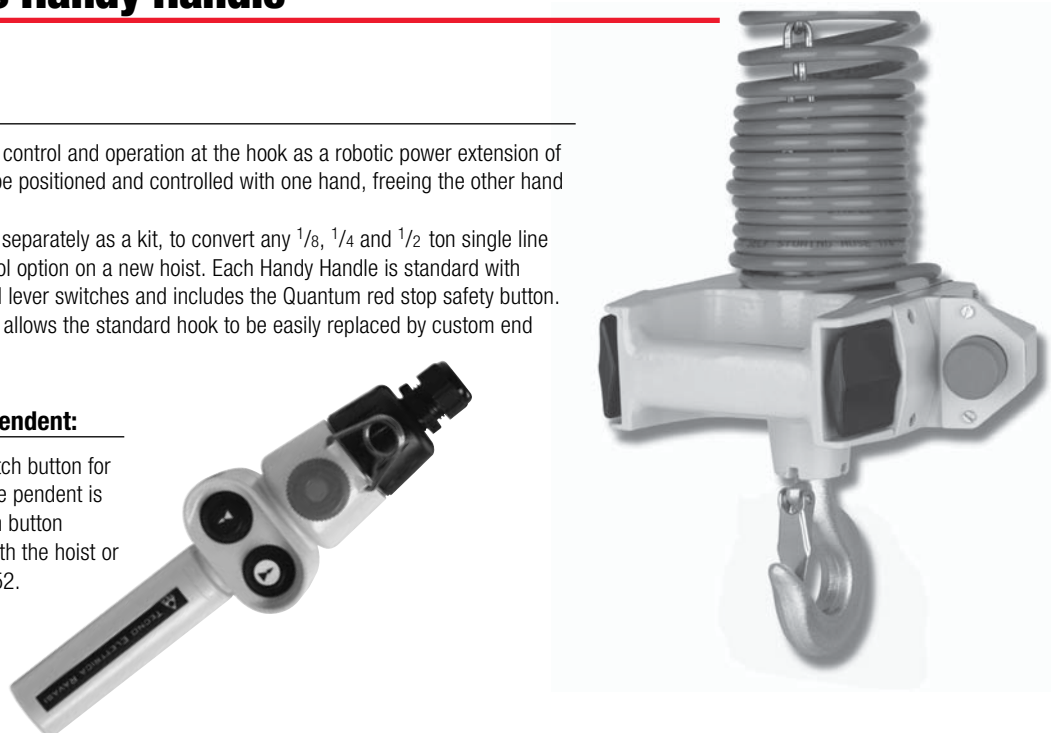

Quantum Series Electric Chain Hoist

1/8 – 5 metric ton Lifting Capacity

Quantum Series Dimensions (in.)

Base model	Capacity metric tons	Eye bolt AE	Hook mount AH	Push trolley AP	Motor trolley AM	B	C	D	E	F	G	H	I	J	K
Single Phase (Single Speed)															
Q50-1NS12	1/8	15 ⁵ / ₈	17 ¹ / ₂	18 ¹ / ₈	n/a	29 ² / ₃₂	1 ¹ / ₈	1 ¹ / ₈	1 ⁵ / ₈	5/8	10 ²⁹ / ₃₂	7 ³ / ₁₆	6 ¹ / ₈	5 ⁵ / ₈	2 ¹ / ₈
Q50-1NS25	1/4	16 ³ / ₁₆	18 ¹³ / ₃₂	18 ³ / ₄	n/a	1	1 ¹ / ₈	1 ¹ / ₈	1 ⁵ / ₈	5/8	10 ²⁹ / ₃₂	7 ³ / ₁₆	6 ¹ / ₈	5 ³ / ₄	2 ¹ / ₈
Q50-1NS50	1/2	16 ³ / ₁₆	18 ¹³ / ₃₂	18 ³ / ₄	n/a	1	1 ¹ / ₈	1 ¹ / ₈	1 ⁵ / ₈	5/8	10 ²⁹ / ₃₂	7 ³ / ₁₆	6 ¹ / ₈	5 ³ / ₄	2 ¹ / ₈
Q100-1NS50	1/2	19 ¹ / ₈	21 ¹ / ₂	21 ⁵ / ₈	n/a	1 ³ / ₁₆	1 ³ / ₈	1 ³ / ₁₆	2	5/8	12 ¹³ / ₃₂	9 ¹ / ₈	7 ⁵ / ₁₆	8 ¹ / ₈	3
Q50-2NS100	1	16 ³ / ₁₆	18 ¹³ / ₃₂	18 ³ / ₄	n/a	1	1 ¹ / ₈	1 ¹ / ₈	1 ⁵ / ₈	5/8	10 ²⁹ / ₃₂	7 ³ / ₁₆	6 ¹ / ₈	6 ³ / ₄	2 ¹ / ₈
Q100-2NS100	1	22	24 ¹ / ₂	24 ¹ / ₂	n/a	1 ³ / ₁₆	1 ³ / ₈	1 ³ / ₁₆	2	1 ³ / ₁₆	12 ¹³ / ₃₂	9 ¹ / ₈	7 ⁵ / ₁₆	9 ¹ / ₂	3
Q200-1NS100	1	21 ¹³ / ₁₆	22 ³ / ₁₆	24 ⁵ / ₁₆	n/a	1 ¹ / ₂	1 ¹ / ₂	1 ⁵ / ₈	3	1/2	15 ¹ / ₈	9 ¹³ / ₃₂	8 ¹³ / ₁₆	9 ¹³ / ₁₆	5 ¹³ / ₃₂
Q200-2NS200	2	26 ¹ / ₂	26 ²⁹ / ₃₂	28 ²⁹ / ₃₂	n/a	1 ¹ / ₂	1 ¹ / ₂	1 ⁵ / ₈	3	1/2	15 ¹ / ₈	9 ¹³ / ₃₂	8 ¹³ / ₁₆	11 ¹ / ₂	5 ¹³ / ₃₂
Q500-1NS200	2	21 ²⁹ / ₃₂	22 ⁵ / ₁₆	24 ¹³ / ₃₂	n/a	1 ¹ / ₂	1 ¹ / ₂	1 ⁵ / ₈	3	1/2	15 ¹ / ₈	9 ¹³ / ₃₂	8 ¹³ / ₁₆	9 ²⁹ / ₃₂	5 ¹³ / ₃₂
Q500-2NS300	3	26 ³ / ₄	27 ¹ / ₈	29 ⁵ / ₁₆	n/a	1 ¹ / ₂	1 ¹ / ₂	1 ⁵ / ₈	3	1/2	15 ¹ / ₈	9 ¹³ / ₃₂	8 ¹³ / ₁₆	11 ¹ / ₂	5 ¹³ / ₃₂
Q500-2NS400	4	26 ³ / ₄	27 ¹ / ₈	29 ⁵ / ₁₆	n/a	1 ¹ / ₂	1 ¹ / ₂	1 ⁵ / ₈	3	1/2	15 ¹ / ₈	9 ¹³ / ₃₂	8 ¹³ / ₁₆	11 ¹ / ₂	5 ¹³ / ₃₂
Three phase (Single and Dual speed)															
Q50-1NS12	1/8	15 ⁵ / ₈	17 ¹ / ₂	18 ¹ / ₈	17 ¹ / ₂	29 ² / ₃₂	1 ¹ / ₈	1 ¹ / ₈	1 ⁵ / ₈	5/8	10 ²⁹ / ₃₂	7 ³ / ₁₆	6 ¹ / ₈	5 ⁵ / ₈	2 ¹ / ₈
Q50-1NS25	1/4	15 ⁵ / ₈	17 ¹ / ₂	18 ¹ / ₈	17 ¹ / ₂	29 ² / ₃₂	1 ¹ / ₈	1 ¹ / ₈	1 ⁵ / ₈	5/8	10 ²⁹ / ₃₂	7 ³ / ₁₆	6 ¹ / ₈	5 ⁵ / ₈	2 ¹ / ₈
Q50-1HS25	1/4	16 ³ / ₁₆	18 ¹³ / ₃₂	18 ³ / ₄	18 ¹ / ₈	1	1 ¹ / ₈	1 ¹ / ₈	1 ⁵ / ₈	5/8	10 ²⁹ / ₃₂	7 ³ / ₁₆	6 ¹ / ₈	5 ³ / ₄	2 ¹ / ₈
Q50-1NS50	1/2	16 ³ / ₁₆	18 ¹³ / ₃₂	18 ³ / ₄	18 ¹ / ₈	1	1 ¹ / ₈	1 ¹ / ₈	1 ⁵ / ₈	5/8	10 ²⁹ / ₃₂	7 ³ / ₁₆	6 ¹ / ₈	5 ³ / ₄	2 ¹ / ₈
Q100-1HS50	1/2	19 ¹ / ₈	21 ¹ / ₂	21 ⁵ / ₈	21 ¹³ / ₃₂	1 ³ / ₁₆	1 ³ / ₈	1 ³ / ₁₆	2	1 ³ / ₁₆	12 ¹³ / ₃₂	9 ¹ / ₈	7 ⁵ / ₁₆	8 ¹ / ₈	3
Q50-2NS100	1	16 ³ / ₁₆	18 ¹³ / ₃₂	18 ³ / ₄	18 ¹ / ₈	1	1 ¹ / ₈	1 ¹ / ₈	1 ⁵ / ₈	5/8	10 ²⁹ / ₃₂	7 ³ / ₁₆	6 ¹ / ₈	6 ³ / ₄	2 ¹ / ₈
Q100-1NS100	1	19 ¹ / ₈	21 ¹ / ₂	21 ⁵ / ₈	21 ¹³ / ₃₂	1 ³ / ₁₆	1 ³ / ₈	1 ³ / ₁₆	2	1 ³ / ₁₆	12 ¹³ / ₃₂	9 ¹ / ₈	7 ⁵ / ₁₆	8 ¹ / ₈	3
Q100-2NS100	2	22	26 ¹ / ₈	24 ¹ / ₂	24 ¹³ / ₃₂	1 ³ / ₁₆	1 ³ / ₈	1 ³ / ₁₆	2	1 ³ / ₁₆	12 ¹³ / ₃₂	9 ¹ / ₈	7 ⁵ / ₁₆	9 ¹ / ₂	3
Q300-1NS200	2	21 ²⁹ / ₃₂	22 ⁵ / ₁₆	24 ¹³ / ₃₂	24 ¹ / ₈	1 ¹ / ₂	1 ¹ / ₂	1 ⁵ / ₈	3	1/2	15 ¹ / ₈	9 ¹³ / ₃₂	8 ¹³ / ₁₆	9 ²⁹ / ₃₂	5 ¹³ / ₃₂
Q200-2NS300	3	26 ¹ / ₂	26 ²⁹ / ₃₂	29 ¹ / ₈	28 ⁵ / ₈	1 ¹ / ₂	1 ¹ / ₂	1 ⁵ / ₈	3	1/2	15 ¹ / ₈	9 ¹³ / ₃₂	8 ¹³ / ₁₆	11 ¹ / ₂	5 ¹³ / ₃₂
Q300-2NS400	4	26 ¹ / ₂	26 ²⁹ / ₃₂	29	28 ⁵ / ₈	1 ¹ / ₂	1 ¹ / ₂	1 ⁵ / ₈	3	1/2	15 ¹ / ₈	9 ¹³ / ₃₂	8 ¹³ / ₁₆	11 ¹ / ₂	5 ¹³ / ₃₂
Q500-2NS500	5	26 ³ / ₄	27 ¹ / ₈	29 ⁵ / ₁₆	28 ²⁹ / ₃₂	1 ¹ / ₂	1 ¹ / ₂	1 ⁵ / ₈	3	1/2	15 ¹ / ₈	9 ¹³ / ₃₂	8 ¹³ / ₁₆	11 ¹ / ₂	5 ¹³ / ₃₂

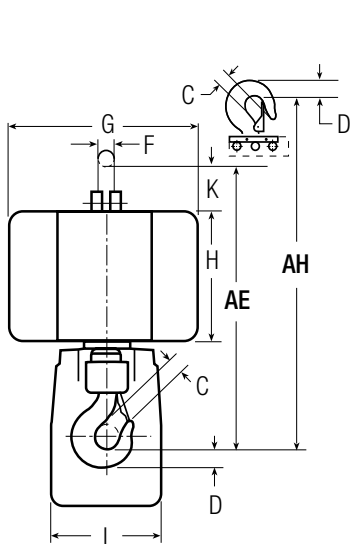

Eyebolt and Hook suspension

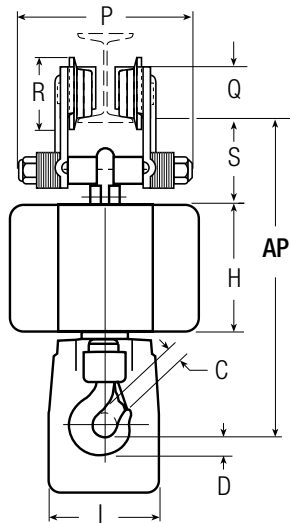
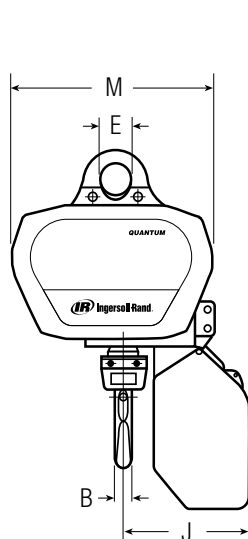

PT Series Plain Trolley with Hook Suspension

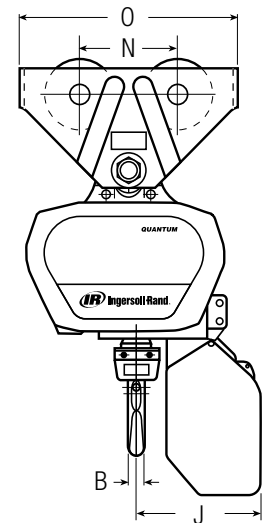

Industrial Lifting Equipment

Quantum Series Electric Chain Hoist



1/8 – 5 metric ton Lifting Capacity

Quantum Series Dimensions (in.)

Base model	Cap. metric tons	L	M	N	O	P	Q	R	S	T	U	V	W	X	Y	Z
Single Phase (Single Speed)																
Q50-1NS12	1/8	6 ¹⁵ / ₁₆	10	4 ¹ / ₂	10	8 ¹⁵ / ₁₆	2 ³ / ₁₆	3 ⁷ / ₁₆	4 ⁵ / ₈	10 ¹ / ₂	8 ³ / ₁₆	2 ³ / ₄	3 ¹³ / ₁₆	4 ³ / ₁₆	8 ⁵ / ₈	2 ³ / ₁₆
Q50-1NS25	1/4	6 ¹⁵ / ₁₆	10	4 ¹ / ₂	10	8 ¹⁵ / ₁₆	2 ³ / ₁₆	3 ⁷ / ₁₆	4 ⁵ / ₈	10 ¹ / ₂	8 ³ / ₁₆	2 ³ / ₄	3 ¹³ / ₁₆	4 ³ / ₁₆	8 ⁵ / ₈	2 ³ / ₁₆
Q50-1NS50	1/2	6 ¹⁵ / ₁₆	10	4 ¹ / ₂	10	8 ¹⁵ / ₁₆	2 ³ / ₁₆	3 ⁷ / ₁₆	4 ⁵ / ₈	1 ¹ / ₂	8 ³ / ₁₆	2 ³ / ₄	3 ¹³ / ₁₆	4 ³ / ₁₆	5 ⁸ / ₁₆	2 ³ / ₁₆
Q100-1NS50	1/2	11	12 ³ / ₄	4 ¹ / ₂	10	8 ¹⁵ / ₁₆	2 ³ / ₁₆	3 ⁷ / ₁₆	5 ¹ / ₂	10 ⁵ / ₈	8 ⁵ / ₁₆	3 ³ / ₁₆	4 ³ / ₁₆	4 ¹³ / ₁₆	9 ¹³ / ₁₆	1 ¹ / ₂
Q50-2NS100	1	6 ¹⁵ / ₁₆	10	5 ⁵ / ₈	12 ⁵ / ₈	10	2 ¹³ / ₁₆	4 ³ / ₁₆	4 ⁵ / ₈	10 ¹ / ₂	8 ³ / ₁₆	2 ³ / ₄	3 ¹³ / ₁₆	4 ³ / ₁₆	8 ⁵ / ₈	2 ³ / ₁₆
Q100-2NS100	1	11	12 ³ / ₄	5 ⁵ / ₈	12 ⁵ / ₈	10	2 ¹³ / ₁₆	4 ³ / ₁₆	5 ¹ / ₂	10 ⁵ / ₈	8 ³ / ₁₆	3 ³ / ₁₆	4 ³ / ₁₆	4 ¹³ / ₁₆	9 ¹³ / ₁₆	1 ¹ / ₂
Q200-1NS100	1	12 ³ / ₄	13 ³ / ₁₆	5 ⁵ / ₈	12 ⁵ / ₈	10	2 ¹³ / ₁₆	4 ³ / ₁₆	7 ¹⁵ / ₁₆	10 ¹³ / ₁₆	8 ¹ / ₂	4	4 ³ / ₄	5 ²⁹ / ₃₂	12 ² / ₁₆	5 ¹ / ₁₆
Q200-2NS200	2	12 ³ / ₄	13 ³ / ₁₆	6 ¹ / ₂	14 ¹⁵ / ₁₆	11 ³ / ₁₆	4 ⁵ / ₁₆	5 ³ / ₄	7 ¹⁵ / ₁₆	10 ⁵ / ₈	8 ⁵ / ₁₆	3 ³ / ₁₆	4 ³ / ₁₆	4 ¹³ / ₁₆	9 ¹³ / ₁₆	1 ¹ / ₂
Q500-1NS200	2	12 ³ / ₄	13 ³ / ₁₆	6 ¹ / ₂	14 ¹⁵ / ₁₆	11 ³ / ₁₆	4 ⁵ / ₁₆	5 ³ / ₄	7 ¹⁵ / ₁₆	10 ¹³ / ₁₆	8 ¹ / ₂	4	4 ³ / ₄	5 ²⁹ / ₃₂	12 ² / ₁₆	5 ¹ / ₁₆
Q500-2NS300	3	12 ³ / ₄	13 ³ / ₁₆	6 ¹ / ₂	14 ³ / ₁₆	12 ⁷ / ₁₆	4 ⁵ / ₁₆	5 ³ / ₄	8	10 ¹³ / ₁₆	8 ¹ / ₂	4	4 ³ / ₄	5 ²⁹ / ₃₂	12 ² / ₁₆	5 ¹ / ₁₆
Q500-2NS400	4	12 ³ / ₄	13 ³ / ₁₆	6 ³ / ₄	15 ⁷ / ₁₆	14 ¹⁵ / ₁₆	4 ⁷ / ₁₆	6 ³ / ₁₆	8	10 ¹³ / ₁₆	9 ³ / ₄	4	4 ³ / ₄	5 ²⁹ / ₃₂	12 ² / ₁₆	5 ¹ / ₁₆
Three Phase (Single and Dual Speed)																
Q50-1ND12	1/8	6 ¹⁵ / ₁₆	10	4 ¹ / ₂	10	8 ¹⁵ / ₁₆	2 ³ / ₁₆	3 ⁷ / ₁₆	4 ⁵ / ₈	10 ¹ / ₂	8 ³ / ₁₆	2 ³ / ₄	3 ¹³ / ₁₆	4 ³ / ₁₆	8 ⁵ / ₈	2 ³ / ₁₆
Q50-1ND25	1/4	6 ¹⁵ / ₁₆	10	4 ¹ / ₂	10	8 ¹⁵ / ₁₆	2 ³ / ₁₆	3 ⁷ / ₁₆	4 ⁵ / ₈	10 ¹ / ₂	8 ³ / ₁₆	2 ³ / ₄	3 ¹³ / ₁₆	4 ³ / ₁₆	8 ⁵ / ₈	2 ³ / ₁₆
Q50-1HD25	1/4	6 ¹⁵ / ₁₆	10	4 ¹ / ₂	10	8 ¹⁵ / ₁₆	2 ³ / ₁₆	3 ⁷ / ₁₆	4 ⁵ / ₈	10 ¹ / ₂	8 ³ / ₁₆	2 ³ / ₄	3 ¹³ / ₁₆	4 ³ / ₁₆	8 ⁵ / ₈	2 ³ / ₁₆
Q50-1ND50	1/2	6 ¹⁵ / ₁₆	10	4 ¹ / ₂	10	8 ¹⁵ / ₁₆	2 ³ / ₁₆	3 ⁷ / ₁₆	4 ⁵ / ₈	1 ¹ / ₂	8 ³ / ₁₆	2 ³ / ₄	3 ¹³ / ₁₆	4 ³ / ₁₆	5 ⁸ / ₁₆	2 ³ / ₁₆
Q100-1HD50	1/2	11	12 ³ / ₄	4 ¹ / ₂	10	8 ¹⁵ / ₁₆	2 ³ / ₁₆	3 ⁷ / ₁₆	5 ¹ / ₂	10 ⁵ / ₈	8 ⁵ / ₁₆	3 ³ / ₁₆	4 ³ / ₁₆	4 ¹³ / ₁₆	9 ¹³ / ₁₆	1 ¹ / ₂
Q50-2ND100	1	6 ¹⁵ / ₁₆	10	5 ⁵ / ₈	12 ⁵ / ₈	10	2 ¹³ / ₁₆	4 ³ / ₁₆	4 ⁵ / ₈	10 ¹ / ₂	8 ³ / ₁₆	2 ³ / ₄	3 ¹³ / ₁₆	4 ³ / ₁₆	8 ⁵ / ₈	2 ³ / ₁₆
Q100-1ND100	1	11	12 ³ / ₄	5 ⁵ / ₈	12 ⁵ / ₈	10	2 ¹³ / ₁₆	4 ³ / ₁₆	5 ¹ / ₂	10 ⁵ / ₈	8 ⁵ / ₁₆	3 ³ / ₁₆	4 ³ / ₁₆	4 ¹³ / ₁₆	9 ¹³ / ₁₆	1 ¹ / ₂
Q100-2ND100	2	11	12 ³ / ₄	6 ¹ / ₂	14 ¹⁵ / ₁₆	11 ³ / ₁₆	4 ⁵ / ₁₆	5 ³ / ₄	5 ¹ / ₂	10 ⁵ / ₈	8 ⁵ / ₁₆	3 ³ / ₁₆	4 ³ / ₁₆	4 ¹³ / ₁₆	9 ¹³ / ₁₆	1 ¹ / ₂
Q300-1ND200	2	12 ³ / ₄	13 ³ / ₁₆	6 ¹ / ₂	14 ¹⁵ / ₁₆	11 ³ / ₁₆	4 ⁵ / ₁₆	5 ³ / ₄	7 ¹⁵ / ₁₆	10 ¹³ / ₁₆	8 ¹ / ₂	4	4 ³ / ₄	5 ²⁹ / ₃₂	12 ² / ₁₆	5 ¹ / ₁₆
Q200-2ND300	3	12 ³ / ₄	13 ³ / ₁₆	6 ¹ / ₂	14 ³ / ₁₆	14 ⁹ / ₁₆	4 ⁵ / ₁₆	5 ³ / ₄	8	10 ¹³ / ₁₆	8 ¹ / ₂	4	4 ³ / ₄	5 ²⁹ / ₃₂	12 ² / ₁₆	5 ¹ / ₁₆
Q300-2ND400	4	12 ³ / ₄	13 ³ / ₁₆	6 ³ / ₄	15 ⁷ / ₁₆	14 ¹⁵ / ₁₆	4 ⁷ / ₁₆	6 ³ / ₁₆	8	10 ¹³ / ₁₆	8 ¹ / ₂	4	4 ³ / ₄	5 ²⁹ / ₃₂	12 ² / ₁₆	5 ¹ / ₁₆
Q500-2ND500	5	12 ³ / ₄	13 ³ / ₁₆	6 ³ / ₄	15 ⁷ / ₁₆	14 ¹⁵ / ₁₆	4 ⁷ / ₁₆	6 ³ / ₁₆	8	10 ¹³ / ₁₆	9 ³ / ₄	4	4 ³ / ₄	5 ²⁹ / ₃₂	12 ² / ₁₆	5 ¹ / ₁₆

Notes:
Multiply speeds shown by .83 for 380V / 50 Hz units.

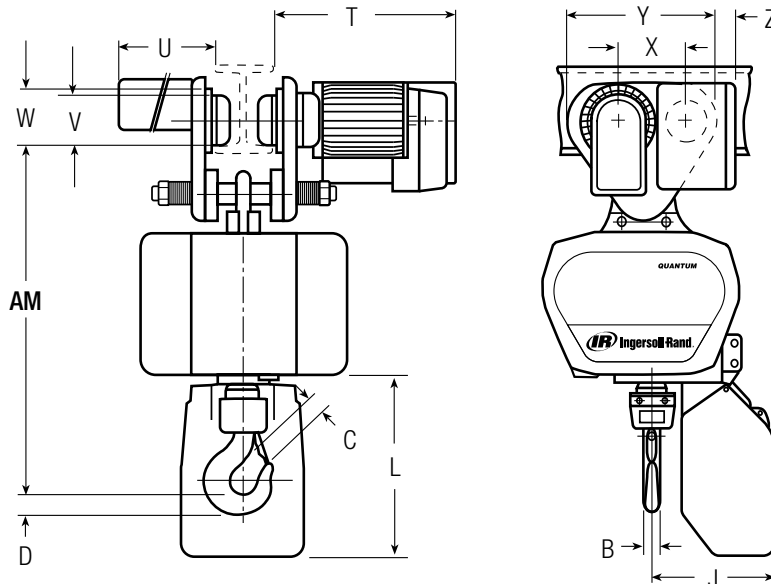

Motorized Trolley Suspension

ULE2 and ULA2 Ultra-Lo Series Chain Hoist

1/4 – 24 US Ton Lifting Capacity

Features:

Ingersoll-Rand's complete line of worm gear driven electric and air low headroom hoists provide smooth, quiet, trouble-free operation. Tested in accordance with ANSI B30.16 overhead hoist standards.

- Large diameter chain wheels for improved chain wear.
- Worm gear drive for maximum control and durability.
- Plain, motorized, and hand chain trolleys.
- Dual up and down limits for added safety.
- NEMA-12 control enclosure and weather resistant Pendant controls.
- Design flexibility allows custom configurations to be offered and priced on request.
- Dual braking from the self-braking worm drive and spring applied motor brake.
- Explosion-Proof units and spark and corrosion resistant features can be customer defined to fit the most demanding applications and priced on request.
- Quick response time to quotes and reduced lead-time on delivery.

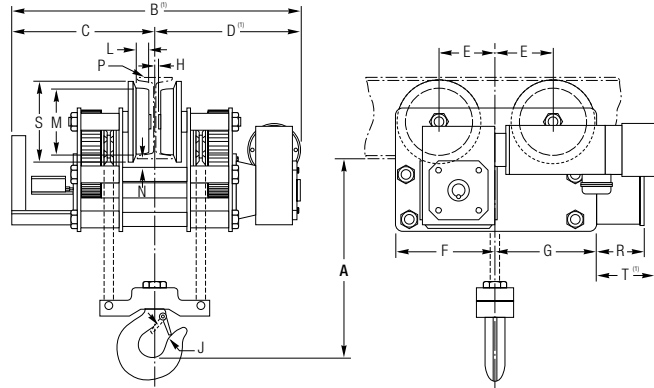

Also offered as ULA2 air chain hoist.
Contact Technical Sales for more information.

ULE2 Electric Series Specifications⁽³⁾

Model no.	Capacity		Hoist speed ft	Motor tly speed fpm	Motor hp (kw) @ rpm	Min curve ² radius ft	Net weight		
	US tons	kg					Plain lbs	Geared lbs	Motorized lbs
ULE2_010-8-6	1	909	10	35	2 (1.5) @1800	6.5	440	470	480
ULE2_015-8-6	1 1/2	1364	10	35	2 (1.5) @1800	6.5	440	470	480
ULE2_020-8-6	2	1818	10	35	2 (1.5) @1800	6.5	440	470	480
ULE2_030-8-6	3	2727	5	35	2 (1.5) @1800	6.5	540	570	580
ULE2_040-8-6	4	3636	5	35	2 (1.5) @1800	6.5	540	570	580
ULE2_050-8-6	5	4545	7	35	4 (3.0) @1200	8.5	1280	1340	1310
ULE2_060-8-6	6	5455	7	35	4 (3.0) @1200	8.5	1280	1340	1310
ULE2_080-8-6	8	7273	4	20	4 (3.0) @1200	9.5	1350	1480	1400
ULE2_100-8-6	10	9091	3.5	20	4 (3.0) @1200	10.0	1730	1810	1780
ULE2_120-8-6 ¹	12	10909	3.5	20	4 (3.0) @1200	n/a	1730	1810	1780
ULE2_160-8-6 ¹	16	14545	2	20	4 (3.0) @1200	n/a	2300	2380	2350
ULE2_200-8-6 ¹	20	18182	1.7	20	4 (3.0) @1200	n/a	2650	2810	2750
ULE2_240-8-6 ¹	24	21818	1.7	20	4 (3.0) @1200	n/a	2650	2810	2750

Notes:

Standard lift is 10 ft.

(1) For over 10 U.S. Ton capacity, straight track operation is recommended.

(2) Curve radius must be specified on orders, since wheels must be modified to negotiate curves. Curves less than minimum radius may be fitted upon application. Consult Customer Service for further information.

(3) ULA2 air hoist specifications and dimensions are similar. Consult Customer Service if accurate data is required.

ULE2 Electric Series Dimensions⁽³⁾ (in.)

Capacity U.S. Tons	A (min)	B	C	D	E	E1	F	G	H	J	L	M	N	P ¹	R	S	T ²
ULE2_010-8-6	7	33	16 1/2	16 1/2	7 3/4	7 3/4	12	10	5/8	1 1/8	1 1/8	4 1/2	15/16	6" I@ 12.5#	6	6	9 1/4
ULE2_015-8-6	7	33	16 1/2	16 1/2	7 3/4	7 3/4	12	10	5/8	1 1/8	1 1/8	4 1/2	15/16	6" I@ 12.5#	6	6	9 1/4
ULE2_020-8-6	7	33	16 1/2	16 1/2	7 3/4	7 3/4	12	10	5/8	1 1/8	1 1/8	4 1/2	15/16	6" I@ 12.5#	6	6	9 1/4
ULE2_030-8-6	8	33	16 1/2	16 1/2	9	9	14	13	9/16	1 11/32	1 11/32	6 3/8	31/32	8" I@ 18.4#	6	8	5 1/2
ULE2_040-8-6	8 1/2	33	16 1/2	16 1/2	9	9	14	13	9/16	1 11/16	1 11/32	6 3/8	31/32	8" I@ 18.4#	6	8	5 1/2
ULE2_050-8-6	9 1/2	50 1/2	23 1/2	24 7/8	7 3/8	7 3/8	12	15	7/8	1 11/16	1 11/32	7 3/16	15/16	10" I@ 25.4#	6	9	12
ULE2_060-8-6	9 1/2	50 1/2	23 1/2	24 7/8	7 3/8	7 3/8	12	15	7/8	1 11/16	1 11/32	7 3/16	15/16	10" I@ 25.4#	6	9	12
ULE2_080-8-6	12	50 1/2	23 1/2	24 7/8	8 3/8	8 7/8	14	13 1/2	9/16	2 1/16	1 11/16	8 1/4	1 1/8	10" I@ 25.4#	6	10	12
ULE2_100-8-6	12 1/2	50 1/2	23 1/2	24 7/8	8 1/2	9 3/4	15 5/8	14 3/8	9/16	2 1/4	1 3/4	9 3/4	7/8	12" I@ 31.8#	6	11 11/16	10
ULE2_120-8-6	12 1/2	50 1/2	23 1/2	24 7/8	8 1/2	9 3/4	15 5/8	14 3/8	9/16	2 1/4	1 3/4	9 3/4	7/8	12" I@ 31.8#	6	11 11/16	10
ULE2_160-8-6	14 1/2	54 1/2	25 1/2	26 15/16	11 7/8	11 7/8	18 5/8	18 5/8	9/16	3	2	11 3/4	1	15" I@ 42.9#	6	13 1/2	3 1/2
ULE2_200-8-6	18	54 1/2	25 1/2	26 15/16	12 1/8	12 3/8	19 1/4	19	3/4	3 3/8	2	11 3/4	1	18" I@ 54.7#	6	13 1/2	2 1/2
ULE2_240-8-6	18	54 1/2	25 1/2	26 15/16	12 1/8	12 3/8	19 1/4	19	3/4	3 3/8	2	11 3/4	1	18" I@ 54.7#	6	13 1/2	2 1/2

Notes:

(1) Minimum standard I-Beam for proper wheel running clearance. Contact factory for smaller beams. Customer must verify their beam is adequate for applied loads.

(2) For standard motor and brake only.

(3) ULA2 air hoist specifications and dimensions are similar. Consult Customer Service if accurate data is required.

Industrial Lifting Equipment

7740B Series Air Chain Hoist



300 lbs Lifting Capacity

Features:

The 7740B air chain hoist has been engineered for production and utility applications for loads up to 300 lbs.

- Light weight and compact design for ease of movement to different work locations.
- Rotary vane air motor.
- Self-adjusting brake holds load securely.
- May be operated between 60 and 100 psi.
- Pull chain control provides accurate spotting control.
- Standard lift is 10 feet; additional lifts are available.
- Standard pull chain length is 6 feet or 4 feet less than lift.
- Steel snap hooks.
- Hook or eye bolt mounted available.

Options:

- Manual trolley
- Bullard hooks
- Chain basket



7740B Series Specifications

Description	
Rated capacity (lbs)	300
Control type	Pull chain
Suspension	Hook or eyebolt
Falls of chain	1
Lifting speed w/ rated load variable from 1 to...fpm	16
Lowering speed w/ rated load variable from 1 to...fpm	17
Air consumption at max rated load scfm	28
Air inlet size, (in.)	1/4 NPT
Recommended hose size (in.)	3/8 I.D.
Max. length of load chain basket will hold (ft)	
Canvas basket (P/N 44120) for link type load chain	10
Metal basket (P/N 44595) for roller type load chain	10
Load chain type	
Link chain	44523
Weight of hoist (lbs)	15.25
Hook on trolley model	SP005 or PT005

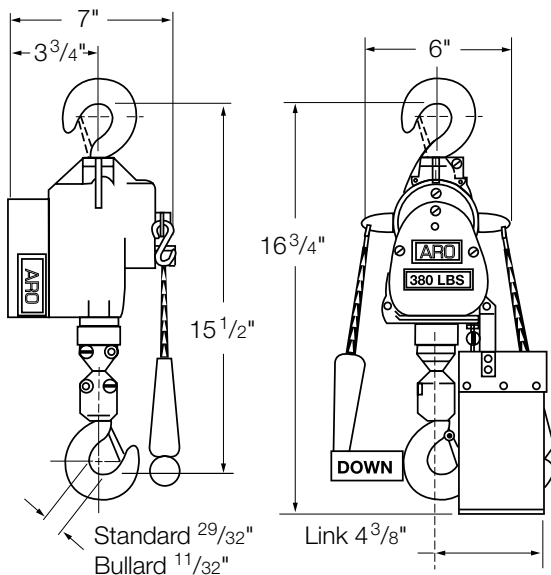

1/4 – 6 metric ton Lifting Capacity

Benefits of using an Ingersoll-Rand air chain hoist:

- 100% duty cycle. Air hoists can be operated continuously, as air motors don't heat up!
- Environment. Dust, dirt, moisture and corrosive gases are kept out of the motor by the air pressure that runs it. This basic fact makes air hoists the first choice in foundries, electroplating shops, etc.
- No electrical hazard. As no electricity is used, the freedom from electrical shock and the use of air power in explosive environments are obvious advantages. This is why air hoists are used extensively in flammable environments found in chemical plants, refineries, etc. Spark resistant models are also available.
- Accurate load spotting. Simple pull chain speed and directional controls provide precise spotting capabilities. Easy to operate pendent air valves provide a variable control signal with adjustable response by a variable orifice. For even more precise control MLKS slow speed models are available.
- Most parts interchangeable. Motor, brake and throttle parts are interchangeable with all current Ingersoll-Rand air chain hoists.
- Low maintenance. Ingersoll-Rand air chain hoists are designed and constructed for trouble-free maintenance. The inherent durability of air power contrasts with the potential problems of electrical systems!

Features:

1. Latch type swivel hooks—top and bottom, meet OSHA requirements, supported by anti-friction roller bearings. Bullard Burnham hooks are available for all models, except spark resistant.
2. Anti-friction bearings. All bearings are either ball or roller type to minimize power-robbing friction.
3. Internal muffler. Reduces sound level to 85 dBA. Located internally in the valve chest for protection against damage. Element is woven to prevent corrosion and clogging.
4. Inlet swivel and strainer. Combined to allow easy hookup from any direction. Swivel reduces hose fatigue, especially on hook-mounted units. Strainer nipple provides that extra assurance of clean air for maximum wear protection.
5. Precision throttle valves. For smooth operation and metering of air. Valves are poppet type for ease of maintenance.
6. 100% Duty Cycle Multi Vane® motor. High torque, low maintenance design with air porting under vanes for smooth operation, positive starting, good control and long life.
7. Control adjustment screws. Provide sensitivity and maximum speed control for pendent models. Adjustment of screws will provide maximum control for each hoisting application.
8. Pull chain control. Provides maximum load spotting capability. Simple conversion from pull chain to pendent control because no internal modification is necessary.
9. Pilot pendent control. Furnishes a variable pressure signal to the valve chest where flow to hoist is metered accordingly. Air to run hoist motor does not travel through pendent, thus pendent length does not affect performance. Control hoses are small, very flexible and easily converted to different lengths.
10. Guarded pendent handle. One-piece, cast-aluminum for maximum durability. Guards on either side of levers are cast-in for protection against accidental operation. All functional parts are of corrosion and spark resistant materials.
11. Two-piece, single-line hook block. Two-piece "clam shell" design entraps chain links and hook bearing without using small load bearing pins or fasteners.
12. Link load chain. Zinc plated steel chain is standard. Stainless steel chain is available for the 1/4 ton through 1 ton spark resistant models.
13. Chain container. Fabric or metal container, as an accessory, to keep slack chain out of the way.
14. Upper and lower limit stops. Prevent dangerous overtravel of the hook in either direction, reducing possible damage to hoist or load.
15. Built-in, cross-link protection. Slack chain is guided into drive wheels by a specially designed opening which prevents dangerous cross-linking of chain.
16. Exhaust air chain lubrication. A small amount of exhaust air flows over chain and drive wheel. This flow helps to lubricate chain from spent in-line lubrication of motor.

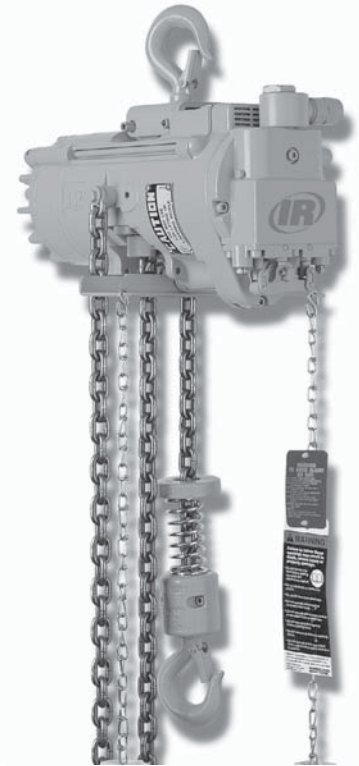

Industrial Lifting Equipment

MLK and HLK Series Air Chain Hoist

1/4 – 6 metric ton Lifting Capacity

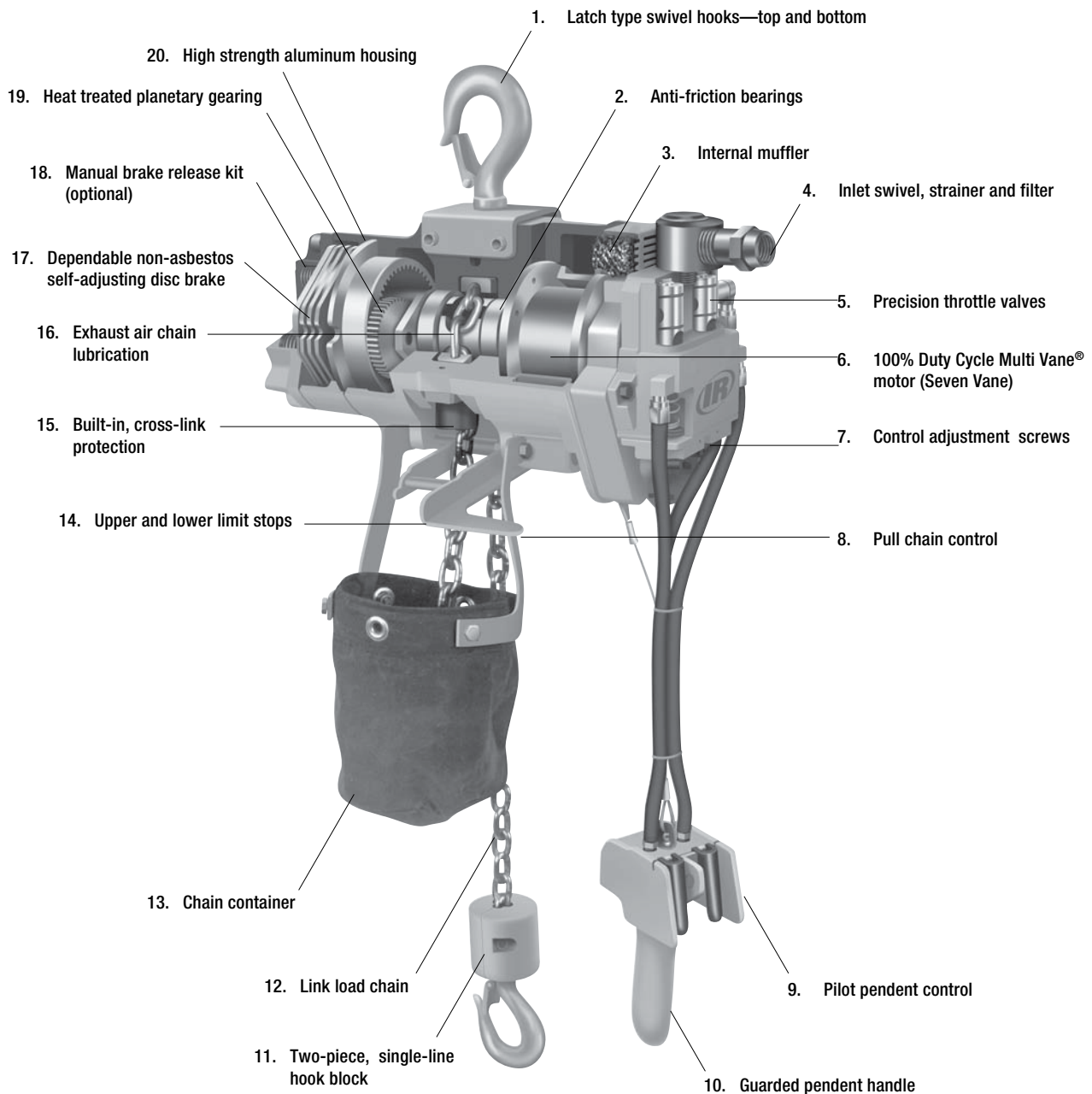

17. Dependable non-asbestos, self-adjusting disc brake. Air-operated disc brake balances brake effort to motor torque by sensing the air pressure in the valve chest. This provides precise control and eliminates back drop problems encountered with some mechanical brakes. If the air supply is interrupted, the pressure release causes instantaneous, automatic braking. The new brake design is protected from impact by a cast housing and is self-adjusting for the full life of the brake.

18. Manual brake release kit. Available as an accessory, this kit allows the operator to safely lower a suspended load in the event of a power failure.

19. Heat-treated planetary gearing. Planetary gearing system provides high torque capability by splitting the torque path, thereby dividing and balancing the load over more teeth. This assures longer life and reduced maintenance.

20. High strength aluminum housing. Strong yet lightweight for maximum portability and weather resistance.

1/4 – 6 metric ton Lifting Capacity

Features:

The MLK family of hoists is suitable for A5/H5 severe duty use in the 1/4 - 1 metric ton range. The MLK is designed to be used as a high speed production hoist; the MLKS* is ideal for slow speed spotting.

The HLK Series uses many of the same components as the MLK family of hoists.

The HLK family incorporates a larger chain wheel to accommodate 3/8 in. diameter chain and a lower gear ratio to handle increased load capacities. HLK series hoists range from 1 through 6 metric tons and are severe duty rated.

Refer to trolley specifications section for plain, geared and motorized trolleys.

Spark-Resistant Features:

MLKR and HLKR spark-resistant hoists have been designed to give maximum protection in explosive or other hazardous environments.

Components for spark-resistance are as follows:

- Bronze hooks.
- Bronze trolley wheels.
- Stainless steel (one part reeving) or aluminum (two part reeving) lower hook blocks.
- Aluminum stop ring (1/4 ton models).
- Stainless steel load chain.
- Stainless steel pendent levers and bronze valve caps.
- Spark-resistant pull chains.

The load capacity and speeds of MLKR and HLKR units are reduced. A restricted motor is used to accomplish this, as stainless steel chain is not hardened and strength is less than standard alloy chain. Refer to trolley section for plain, geared and motorized trolley specifications.

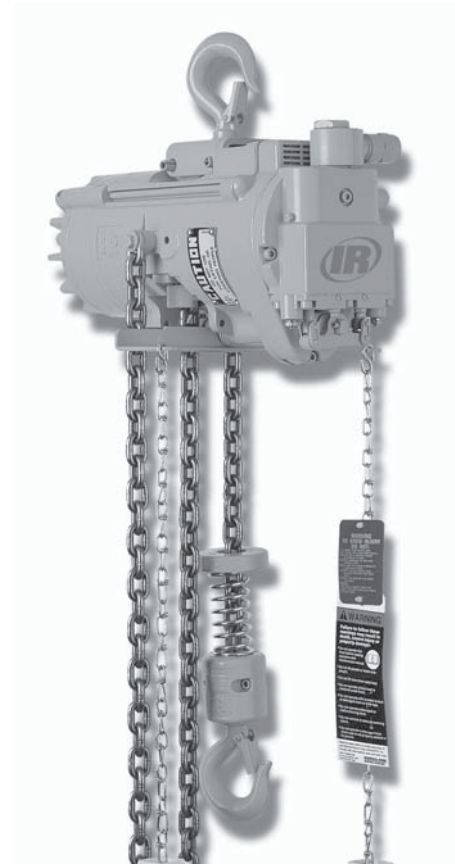

All MLK and HLK Specifications

Model no.	Capacity		No of chain falls	Weight per foot of lift lbs	-2A ¹	-2C ¹	-2D ¹	-2F ¹	-3H
	metric tons	lbs			top lug lbs	top hook lbs	rigid trolley lbs	geared trolley lbs	air trolley lbs
ML250K, KS, KR	1/4	550	1	0.56	48	48	76	101	103
ML500K, KS	1/2	1100	1	0.56	48	48	76	101	103
ML500KR	1/2	1100	2	1.12	61	61	89	114	116
ML1000K, KS	1	2200	2	1.12	61	61	89	114	116
HL1000K, KR	1	2200	1	1.3	86	84	106	109	116
HL1500K	1 1/2	3300	1	1.3	86	84	164	167	174
HL2000K	2	4400	2	2.6	125	125	203	206	213
HL3000K	3	6600	2	2.6	125	125	203	206	213
HL4500K	4 1/2	10000	3	3.9	184	193	392	395	402
HL6000K	6	13200	4	5.2	234	248	442	445	452

Notes:

All weights are for model with 10 feet of lift and pendent.

(1) Pull chain control; deduct 3 lbs where noted.

Industrial Lifting Equipment

MLK and HLK Series Air Chain Hoist



1/4 – 6 metric ton Lifting Capacity

Hoist Operating Data (at 90psi)

Series	Rated load		Half load (fpm)		No load (fpm)	
	up	down	up	down	up	down
MLK and MLKS Series^{1,2}						
ML250KS ³	40.0	90.0	53.0	71.0	71.0	53.0
ML250K	101.0	117.0	145.0	111.0	171.0	99.0
ML500KS ³	22.0	66.0	30.0	44.0	44.0	32.0
ML500K	55.0	97.0	80.0	72.0	106.0	59.0
ML1000KS ³	11.0	33.0	15.0	22.0	22.0	16.0
ML1000K	28.0	49.0	40.0	36.0	53.0	30.0
HLK and HLKR Series^{1,2}						
HL1000K	26.0	37.0	31.0	30.0	40.0	26.0
HL1500K	16.0	26.0	22.0	22.0	28.0	16.0
HL2000K	13.0	18.0	15.0	15.0	20.0	13.0
HL3000K	8.0	13.0	11.0	11.0	14.0	8.0
HL4500K	4.6	10.0	7.5	8.4	10.5	6.6
HL6000K	3.5	7.6	5.8	6.2	8.4	4.8
MLKR and HLKR Series						
ML250KR ³	26.0	38.0	34.0	36.0	42.0	30.0
ML500KR ³	13.0	20.0	17.0	18.0	21.0	15.0
HL1000KR	26.0	37.0	31.0	30.0	40.0	26.0

Notes:

Minimum hose size: 1/2" up to 12 ft long and 3/4" over 12 ft. to 50 ft length.

- (1) MLK and HLK hoist performance is based on 70 cfm at 90 psi air supply at hoist inlet. Pendant control models use approximately 4 scfm more air.
- (2) The ML250KS (1/4 ton), ML500KS (1/2 ton), ML1000KS (1 ton) are standard MLK air chain hoists equipped with special cylinders for slower (S) speeds and "piston motor like" load spotting characteristics.
- (3) MLKS MLKR hoist performance is based on 45 cfm at 90 psi air supply at hoist inlet. Pendant control models use approximately 4 scfm more air.

Chain Container

Hoist Series	Chain capacity ¹ ft.	Metal container part no.	Fabric container part no.
MLK	13	ML10-K749	NA
MLK	17	NA	ML50K-K749-17
MLK	26	ML20-K749A	NA
MLK	40	ML20-K749-20	NA
MLK	45	NA	ML50K-K749-45
MLK	80	MLK-K750-80	NA
HLK	20	HLK-K750-20	HLK-K749-20
HLK	40	HLK-K750-40	HLK-K749-40
HLK	85	HLK-K750-80	NA

Notes:

- (1) Chain containers are for 1 part single lines. For 2 part lines, divide capacity by two; for 3 part lines by three, etc.



Metal Container



Fabric Container

Link Load Chain

Hoist Series	Type	Bulk part no.	Chain size dia/pitch mm
MLK	Zinc plated ¹	M745Z	6.4/19.5
MLK	Stainless Steel ²	M745S	6.4/19.5
HLK	Zinc plated ¹	H745Z	9.5/25.7
HLK	Stainless Steel ²	H745S	9.5/25.7

Notes:

- (1) Standard
- (2) For spark resistant models only

Epoxy Coating

Available on all models. Consists of surface preparation, metal primer and 2 coats of epoxy enamel. Specify separately.

Manual Brake Release Kit (M)

For all MLK and HLK hoists. Part no. MLK-K390

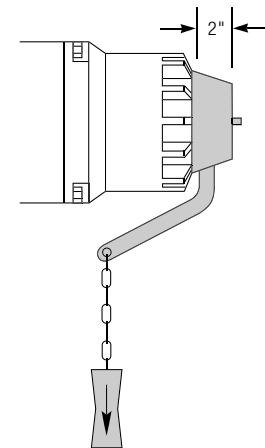

Piped Away Exhaust Kits for MLK and HLK Hoists

Part no. MHLK-KEXH

This two-piece kit replaces swivel air inlet on hoist. Noise is reduced with addition of piped away exhaust hose. Use 1" dia. exhaust hose to minimize reduction in lift speed.

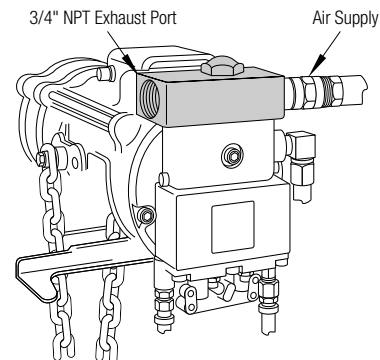

1/4 – 6 metric ton Lifting Capacity

Filters, Regulators, Lubricators

Part no.	Size (in.) NPTF	Flow rate scfm	Adj pressure range psig	Bowl capacity	Height x width in.	Part no.
Filters, Regulators, Lubricators						
C28241-800	1/2	110	5 – 125	6 oz	8 1/4" x 10 7/16"	
C28453-810	3/4	150	5 – 125	32 oz	15 1/4" x 11 3/4"	
C31-08-G00	1	331	10 – 125	24 oz	11" x 12 1/4"	
Filter, Lubricator						
C28241-700	1/2	110	n/a	6 oz	8 1/4" x 5 3/4"	
C28453-810	3/4	150	5 – 125	32 oz	15 1/4" x 11 3/4"	
C36-08-000	1	331	n/a	24 oz	11" x 9 1/4"	

Recoil Nylon Air Hose with Fittings

Part no.	Hose I.D. in.	Max length ft	Hose length working length ft	Compact size in.	Compact coil O.D. in.	Male NPT fitting in.
Swivel both ends						
N12-12B	1/2	12	9	5	9	1/2
N12-25B	1/2	25	18	9	9	1/2
N12-50B	1/2	50	41	18	9	1/2
N34-12B	3/4	12	10	4 1/2	12 1/2	3/4
N34-25B	3/4	2	17	9	12 1/2	3/4
N34-50B	3/4	50	35	16	12 1/2	3/4



Hooks

Hoist series	Cap. metric tons	Bullard-Burnham top or bottom hook part no.	Bronze latch type ¹ top or bottom hook part no.
MLK	1/4	CE110-KBB377	MLK-KRS304
MLK	1/2	CE110-KBB377	ML500KR-K377
MLK	1	CE120-KBB377	–
HLK	1	HLK-ABB377	HLK-SR377
HLK	1 1/2	HLK-ABB377	HL1500K-SR377
HLK	2	HL2000K-ABB377	HL2000K-SR377
HLK	3	HL3000K-ABB377	HL3000K-SR377
HLK	4 1/2	HL4500K-ABB377	HL4500K-SR377
HLK	6	HL6000K-ABB377	HL6000K-SR377

Bullard-Burnham hook



Hose Trolleys

Part no.	Flange width (in.)
7703	2.33 to 5.00
D10-8888	5.00 to 8.75

Note:
Maximum hanging weight per unit is 35 lbs.
Can be adjusted to fit 1/2" to 1 1/4" O.D. hose.



EZ Grip Ergonomic Handle (P/N EZG-A269)

The EZ Grip handle is a rugged, durable construction handle with three mounting options. The handle can be used as a pendent control, rigid mount, or with an optional ball and socket mount. EZ Grip can be used on most air actuated devices, and can be operated with or without gloves.



Optional EZ Grip Pendent Handle

Notes:
Bullard-Burnham hooks are not available for spark resistant models.
(1) Not pictured

Industrial Lifting Equipment MLK and HLK Series Air Chain Hoist



1/4 – 6 metric ton Lifting Capacity

Pendent Handles

Type/ Part no.	NPT air inlet			
	A	B	C	D
Single motor				
MLK-A269C	1/8	1/8	-	-
EZG-A269	3/8	1/8	-	-
MR-269C	3/8	3/8	-	-
C6H20A-A169B	1/2	1/2	-	-
Two motor				
PILOT-A122B	3/8	1/8	1/8	-
MLK-K122B	3/8	1/8	3/8	-
MR-A122C	3/8	3/8	3/8	-
C6H20A-A122B	1/2	1/2	3/8	-
Three motor				
PILOT-A132B	3/8	1/8	1/8	1/8
MLK-K132B	3/8	1/8	3/8	3/8
MR-A132C	3/8	3/8	3/8	3/8
C6H20A-A132B	1/2	1/2	3/8	3/8

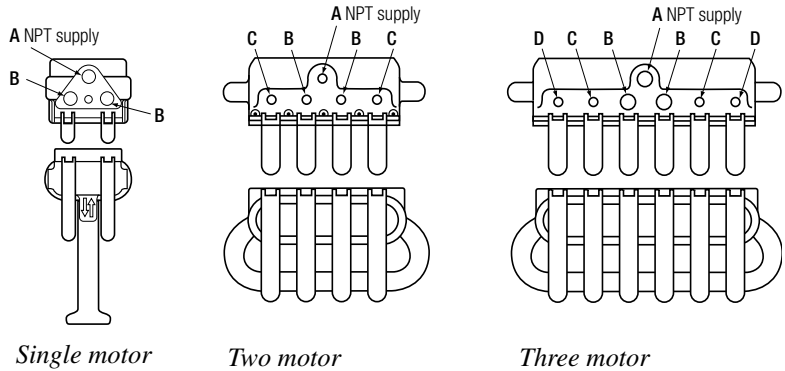

Note:

When a pendent controlled hoist is purchased with a pendent controlled power trolley or tractor, the required two or three motor pendent is furnished at no extra cost in place of the individual pendants, when specified.

Pull Chain Conversion

Part no.	Description
MLK-K415A	Wooden directional and crossbar handles only.
CA110-B240	Standard chain (specify total length of both chains).
DO2-1413	Aluminum spark resistant chain (specify total length of both chains).



Pendent Conversion Kit

Part no.	Description
MLK-AL269C	MLK, HLK and HLKR hoists. Specify length.



Quick Exhaust Valves/for improved response time

Part no.	For use on series	Control type	Style	Pendent length ft	Quantity recommended ¹
20417	All MLK and HLK hoists	Pilot	Push-on	21 – 50	2
20417	HLK hoists		1/4" NPT hose	51 – 75	4
MR-939-6	TIR trolleys	Full flow	Push-on	21 – 50	2
MR-939-6	MTK tractor		3/8" NPT hose	51 – 75	4

Note:

(1) The first pair of full flow valves will be installed between 5 to 7 ft. (1.5 to 2.1 m) from the pendent handle. Any additional valves will equally divide the remaining hose length.

Appx air flow

NPT air inlet	scfm
1/8 in.	15 ¹
3/8 in.	100
1/2 in.	200

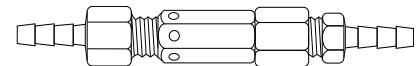

Part no. 20417. Part no. MR-939-6 not shown.

Note:

(1) For pilot air only

Drawbar Hitch Kits for use with MTK Tractor

Series hoist to be towed	Drawbar kit part no.
HL1000K, HL1500K, HL2000K and HL3000K with rigid trolley	No kit required; standard drawbar kit included with MTK tractor fits these hoists
All MLKs with rigid trolley	MR-K1

MLK and HLK Series Air Chain Hoist

1/4 – 1 metric ton Lifting Capacity

MLK, MLKS and MLKR Series Dimensions for 1/4 through 1 ton

1/4 and 1/2 ton MLK Hook Mounted Hoists

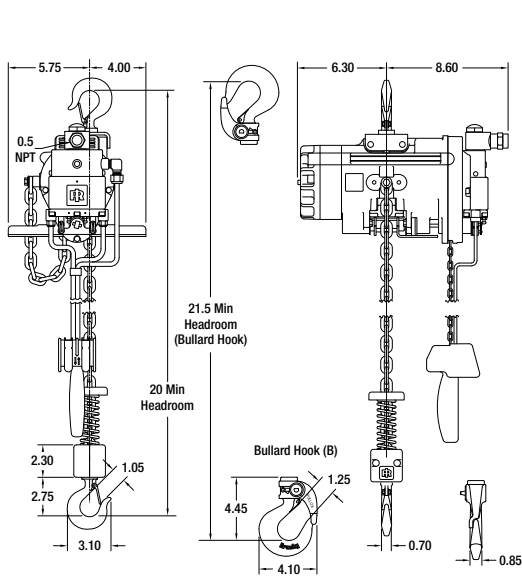

1/4 and 1/2 ton MLK Plain Hook-on Trolley Mounted Hoists

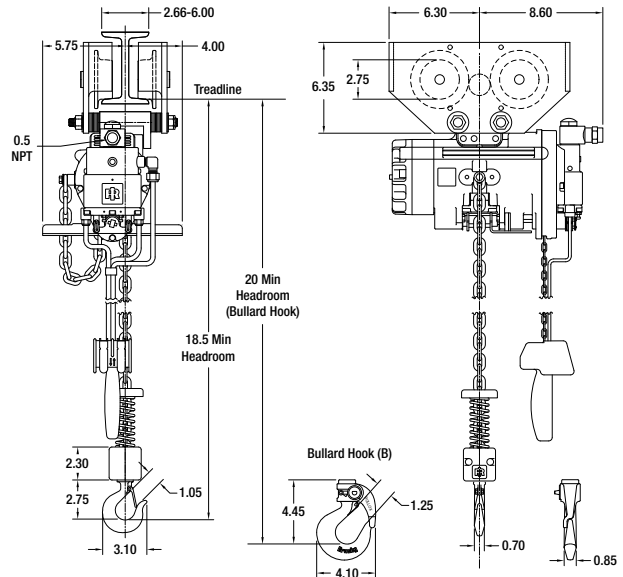

1/4 and 1/2 ton MLK Geared Hook-on Trolley Mounted Hoists

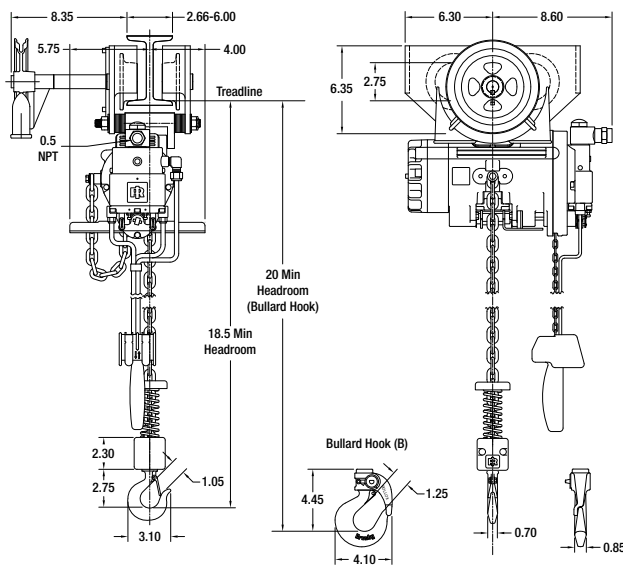

1/4 and 1/2 ton MLK Motorized Trolley Lug Mounted Hoists

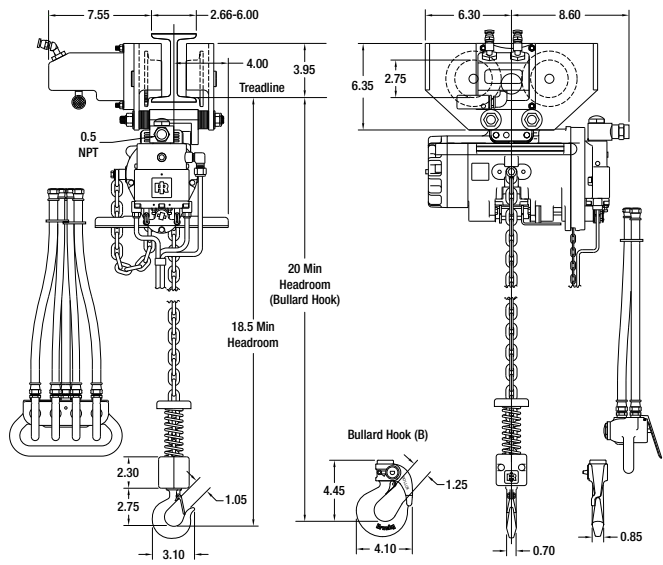

*Chain container capacities are for 1 part single lines. For 2 part lines, divide capacity by 2.

Industrial Lifting Equipment

MLK and HLK Series Air Chain Hoist



1/4 – 1 metric ton Lifting Capacity

MLK, MLKS and MLKR Series Dimensions for 1/4 through 1 ton

1 ton MLK Hook Mounted Hoists

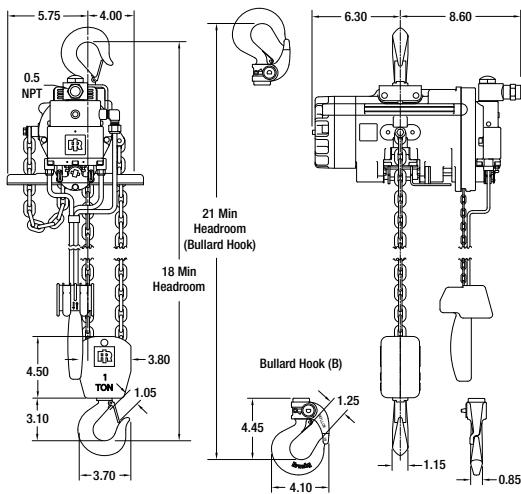

1 ton MLK Plain Hook-on Trolley Mounted Hoists

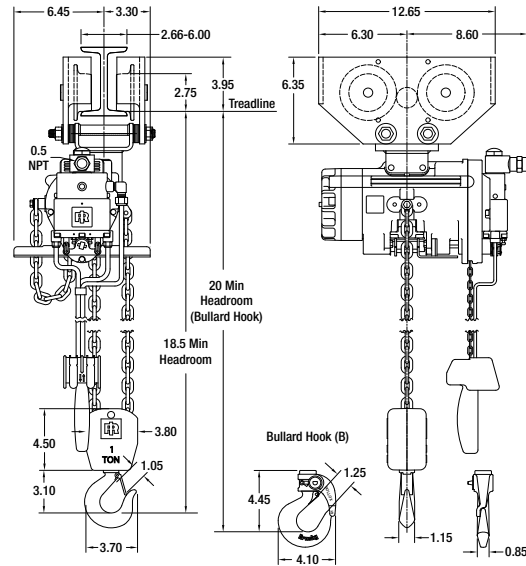

1 ton MLK Geared Hook-on Trolley Mounted Hoists

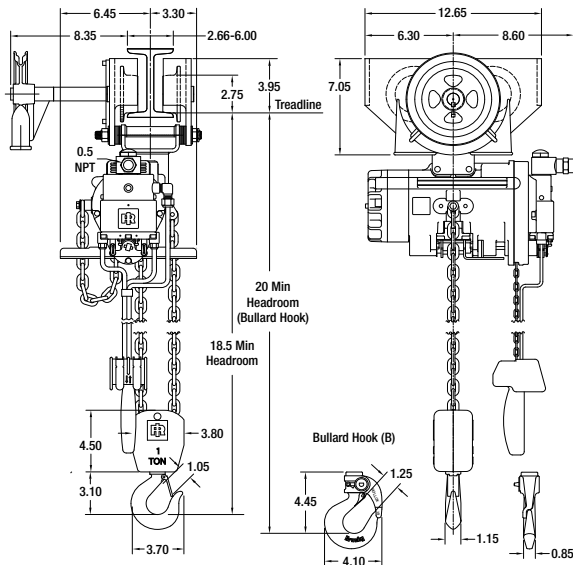

1 ton MLK Motorized Trolley Lug Mounted Hoists

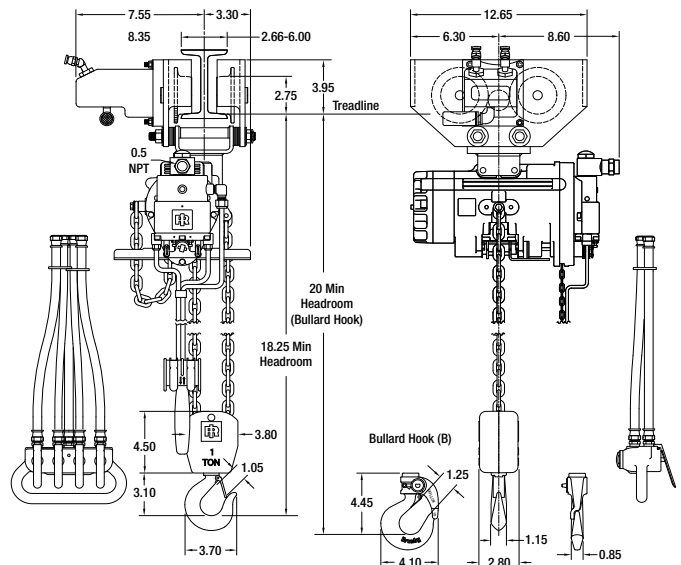

*Chain container capacities are for 1 part single lines. For 2 part lines, divide capacity by 2.

1 – 3 metric ton Lifting Capacity

HLK Series Dimensions for 1 through 3 ton and HLKR Series 1 ton (in.)

Series	A (min)	B	C	D	E	F	G	H	K
HL1000K/R	18 1/2	4 3/4	7 1/4	2 7/16	5 7/16	3 1/2	4 1/2	2 3/8	18 1/8
HL1500K	18 1/2	4 3/4	7 1/4	2 7/16	5 7/16	3 1/2	4 1/2	2 3/8	18 7/8
HL2000K	23	3 5/8	8 3/8	2 3/8	6 9/16	5 3/4	4 1/2	2 3/8	21 5/8
HL3000K	25	3 5/8	8 3/8	2 3/8	6 9/16	6 1/4	4 1/2	2 3/8	22 5/8

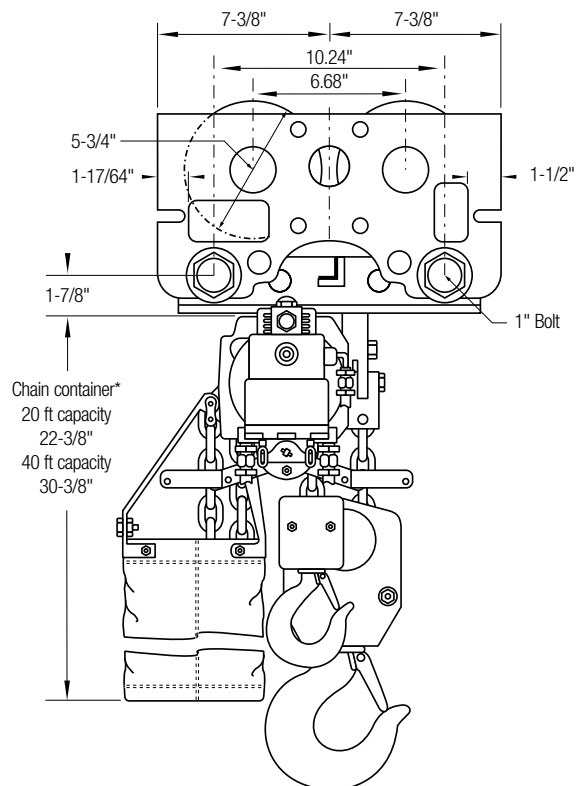
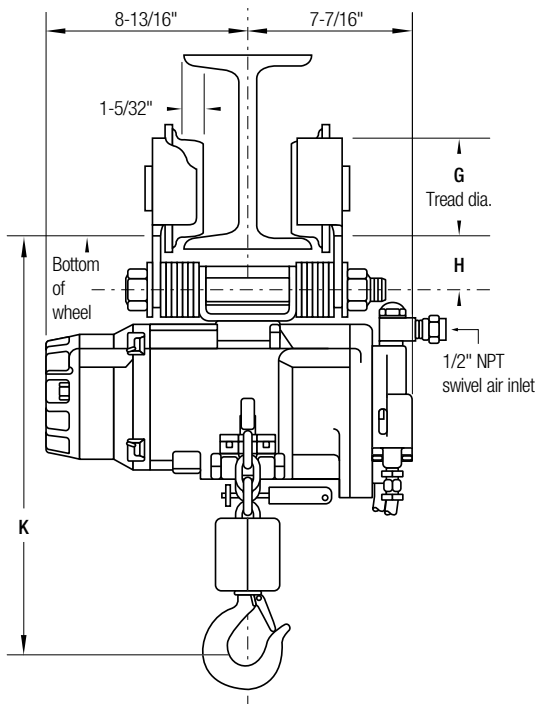
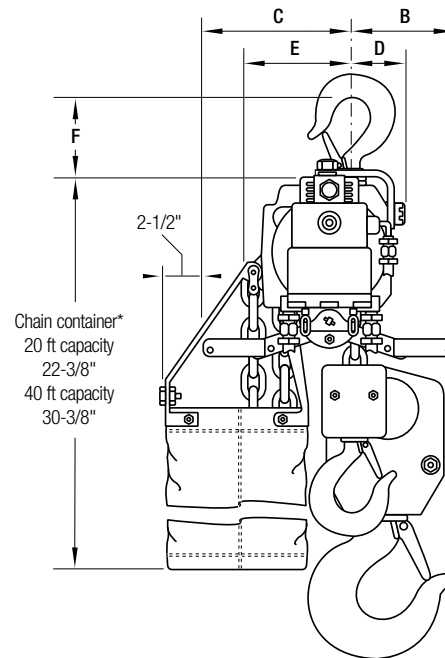
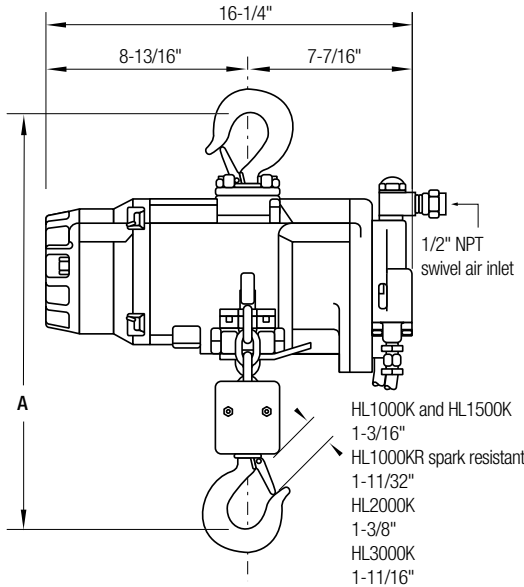

*Chain container capacities are for 1 part single lines (1 and 1 1/2 t). For 2 part lines, divide capacity by 2.

Industrial Lifting Equipment
MLK and HLK Series Air Chain Hoist



4-1/2 – 6 metric ton Lifting Capacity

HLK Series Dimensions for 4 1/2 and 6 ton

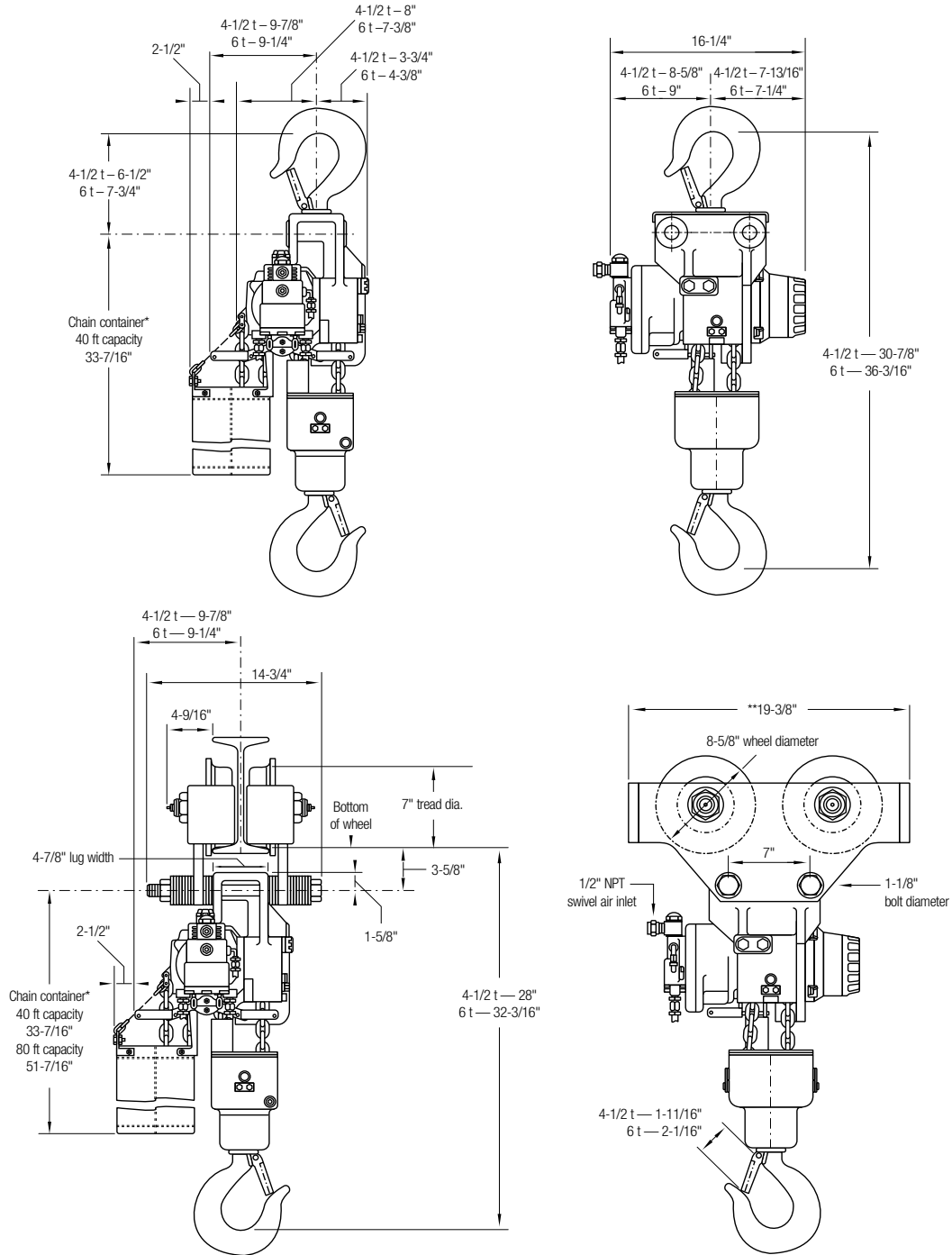

* Chain container capacities are for single line. For 3 part 4 1/2 ton units, divide capacity by 3. For 4 part 6 ton units, divide capacity by 4.
 ** For additional geared and motorized trolley dimensions refer to TIR dimensions in the TIR trolley section.

550 – 2200 lbs Lifting Capacity

NEW DESIGN

Refinements to the Lube-Free Palair and Palair Premium air chain hoists have greatly increased their durability. The Palair Hoists meets the demands of oil free and corrosion resistant applications from food processing to metal foundries.

Standard PAL and PALP Features:

- The Palair Plus lube-free hoist can be operated without supply air lubrication. No oil mist is exhausted to the surrounding environment. Excellent for “clean rooms”, food processing areas, textile industry, or any area where exhaust oil mist cannot be tolerated.
- Gear motor made from a high-strength, durable composite material
- Two moving part motor design provides high reliability and low maintenance.
- Pendant allows variable up and down speeds.
- Ergonomically designed, no external pipes or mechanical linkages.
- **NEW** low pressure disc brake is spring set, air released and is self adjusting for wear.
- Planetary gears for long life and high duty cycle.
- **NEW** high strength polymer chain guide for fast smooth running with minimum wear.
- Limit switches—both upper and lower limit switches are enclosed and protected in the hoist body.
- Load hooks full 360° rotation, on ball bearings for PAL or non-metallic bushings for PALP.
- Internal air exhaust reduces sound levels to below 85 dBA.

Options:

- Trolleys available: hook-on plain, hook-on geared, rigid lug plain, rigid lug geared, and motorized.
- Trolley extension shafts for extended flanges.
- Spark and corrosion resistant options.

Palair Premium PALP Series Features:

The first U.S.D.A. accepted air chain hoist in the United States.

- U.S.D.A. acceptance for meat and poultry equipment as listed in the FSIS Directive 11220.1.
- Corrosion resistance materials - metal parts are either 300 series stainless steel, electroless nickel treated or Nickel Composite finished.
 - Electroless nickel is a high-heat chemical treatment applied to aluminum components and provides high wear durability and will not flake off like paint.
 - 300 series stainless steel is highly corrosion resistant and is used for load hooks, bottom blocks and load chain for models with these stainless steel options.
 - Nickel composite is a FDA approved proprietary finish used on ferrous metals to provide superior resistance to corrosion.
- A combination of stainless steel or electroless nickel hooks, hook blocks, and chain provides spark and corrosion resistance with the lifting parts for your “clean environment” application.
- The gear motor requires no air supply lubrication, therefore exhaust air is as clean and dry as the air supplied.
- Double protected - gear case is sealed and uses U.S.D.A. H-1 type grease.
- All bearings are permanently lubricated and sealed on both sides for U.S.D.A. acceptance.
- Washable and steam cleanable.
- No flaking of paint chips. Nonmetal parts are unpainted to prevent contamination.

Palair™ Premium - goes beyond U.S.D.A. requirements.

- Lubri-Link Green™ - Ingersoll-Rand’s exclusive U.S.D.A. accepted food grade chain lubricant provides the load chain with the recommended protection it needs.
- Trolley hoist applications - Nickel Composite plain hook-on PT-NC series trolley provides the same level of corrosion resistance protection as the hoist.
- Stainless steel piped away exhaust kit allows the exhaust air to be piped away from the application.
- Abrasion, and oil resistant bright yellow pendant hose is highly visible, approved for food contact and easy to clean.

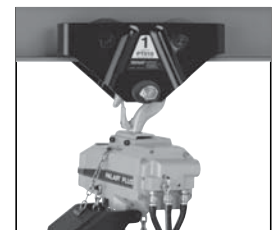
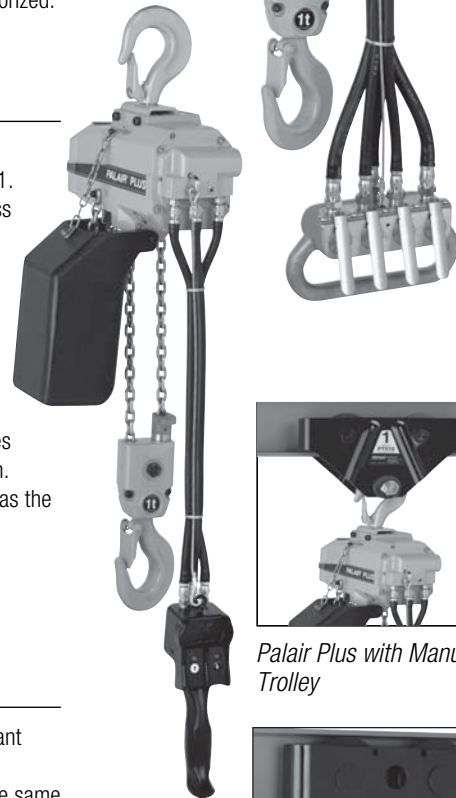
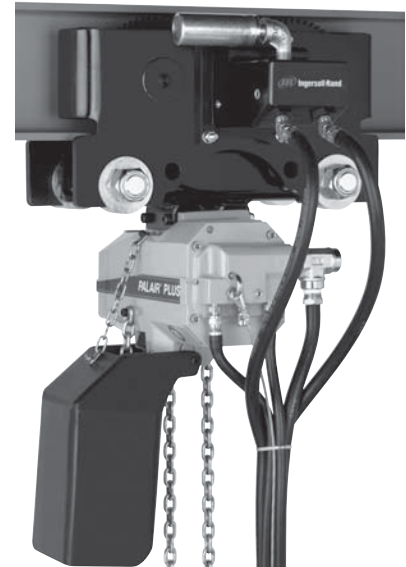

Palair Plus with Manual Trolley

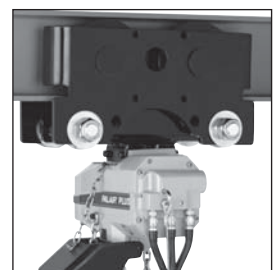

PAL Series Palair PLus Lug Mounted



Industrial Lifting Equipment Palair Series "Lube Free" Air Chain Hoist



550 – 2200 lbs Lifting Capacity

PT Trolley Dimensions (in.)																
Model no.	A	A (-8)	B	C	D	E	F	G	H	J	K	L	N	P (-8)	R	S
PT005-8	2.63	5.88	10	4.5	1	4	1.13	3.5	2.06	0.75	0.75	6.63	3.94	12.25	1.25	1.56
PT010-8	2.5	5.94	13	5.19	1.25	4.44	1.56	4.19	2.75	0.75	1	6.94	4.25	12.88	1.5	1.56

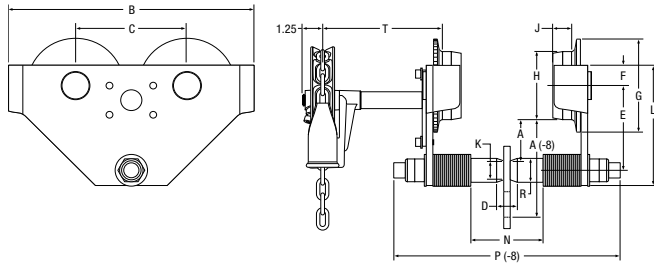

1/2 ton Palair Plus and Palair Premium Hook Mounted Hoists

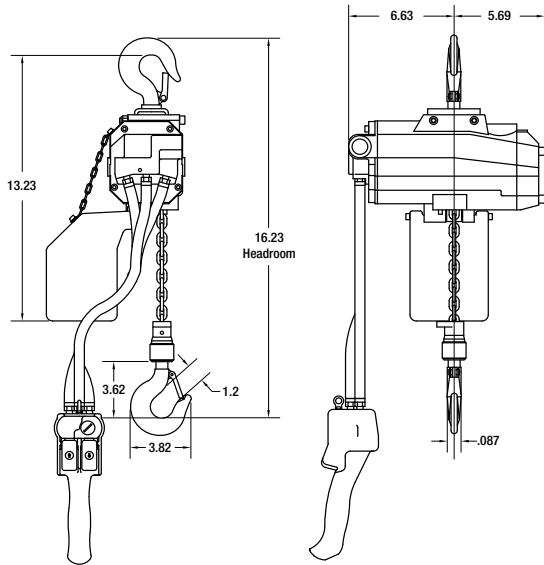

1 ton Palair Plus and Palair Premium Hook Mounted Hoists

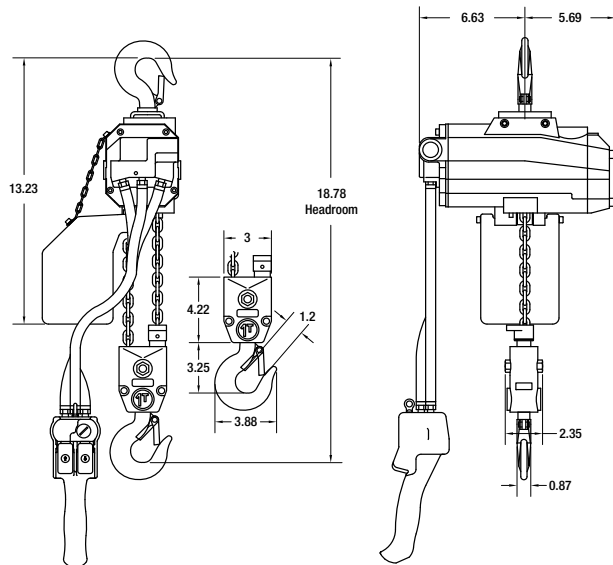

Palair
Premium
Hook
Mounted



PT010-8



Lubri-Link™ Green

Ingersoll-Rand's U.S.D.A. accepted chain lubricant. It's nonaerosol plastic bottle is so environmentally safe it can be air freighted.

- Triples the time between application.
- Triples the life of hoist load chain and sprocket.
- Triples the barrier shield against rust and corrosion.

Palair Series "Lube Free" Air Chain Hoist

550 – 2200 lbs Lifting Capacity

1/2 and 1 ton Palair Plus and Palair Premium Plain Hook-on Trolley Mounted Hoists

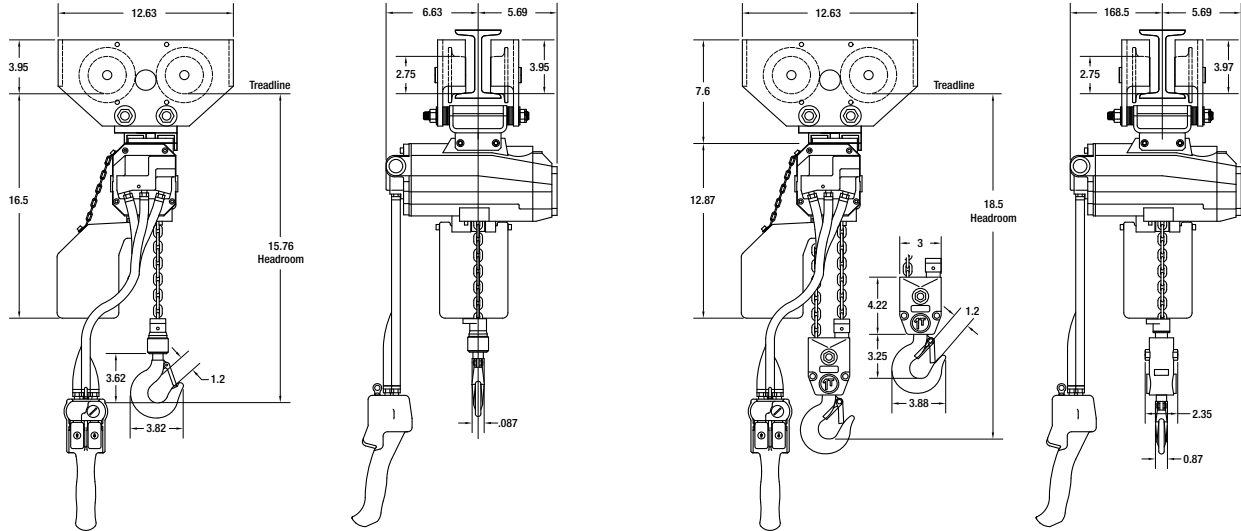

1/2 and 1 ton Palair Plus and Palair Premium Geared Hook-on Trolley Mounted Hoists

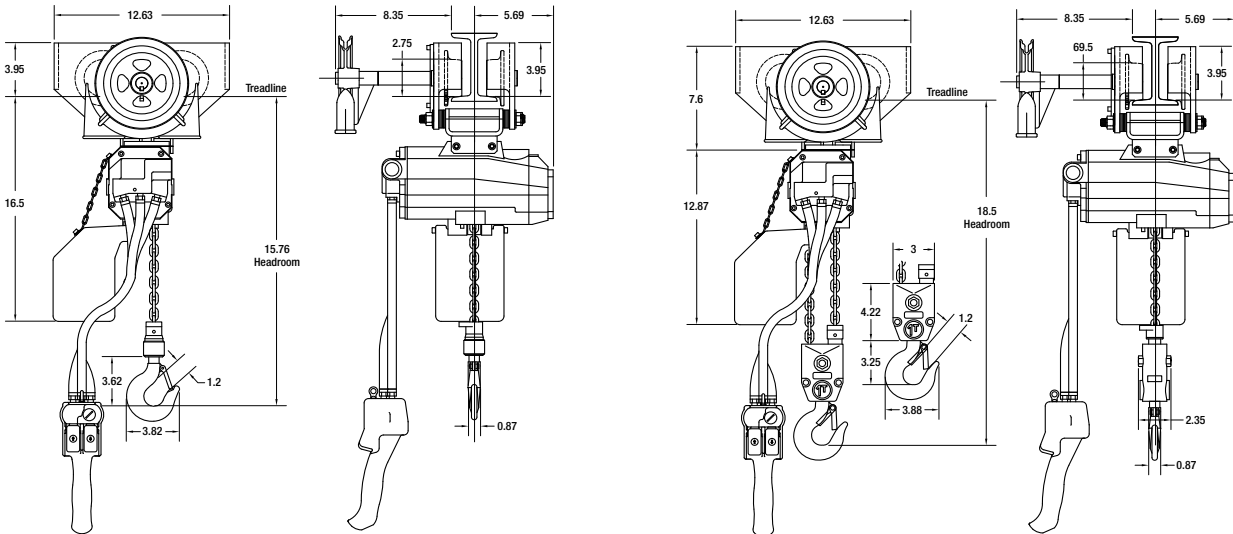

1/2 and 1 ton Palair Plus and Palair Premium Motorized Trolley Lug Mounted Hoists

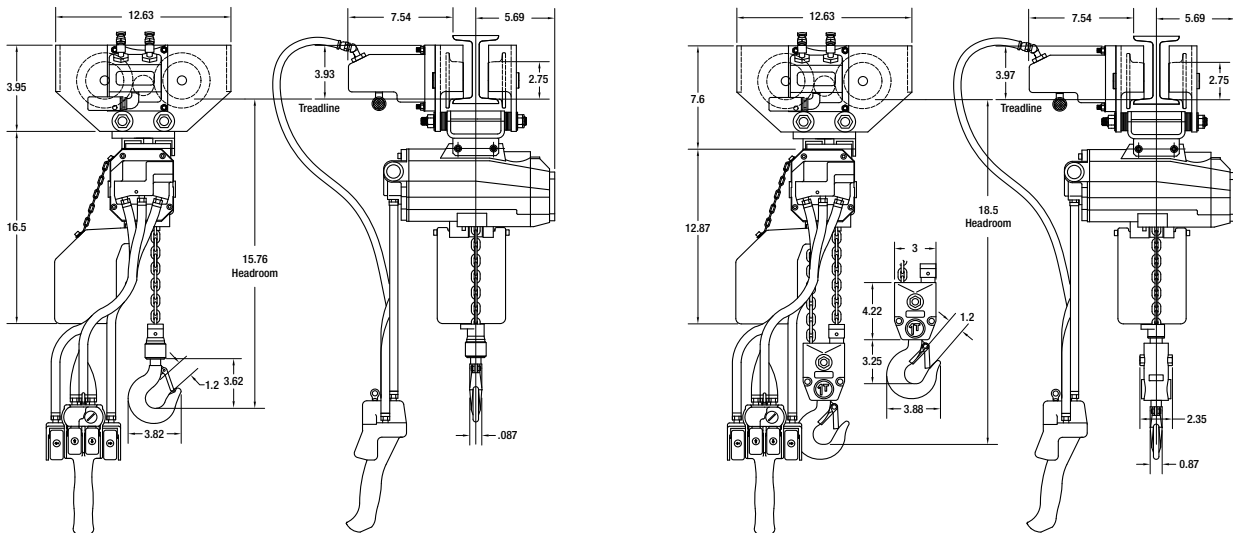

Industrial Lifting Equipment Trolley and Tractor Selection Guide

1/2 – 20 metric ton Lifting Capacity

Ingersoll-Rand offers a wide variety of plain, geared or powered trolleys for use with the MLK and HLK Series air chain hoists. We also offer the MTK air powered tractor to push and pull a trolley mounted hoist or other suspended or supported rolling load.

Ingersoll-Rand trolleys are available in either hook-on or rigid mount style. For maximum convenience and lifting system integrity, it is recommended that the trolley be ordered at the same time as the hoist by using the appropriate model driver suspension code. On the following pages you will find information relating to the various trolleys and the MTK tractor offered by Ingersoll-Rand. The chart below cross references all air chain hoist models and sizes with the recommended trolleys.

Be sure to follow safe installation and operating procedures with any overhead system. Please call an authorized I-R distributor or I-R representative for assistance with application and selection.

Hoist - Trolley Compatibility					
For use with hoist series	Plain hook-on	Plain rigid	Geared hook-on	Geared rigid	Motorized rigid
Standard trolleys (Suspension code)¹					
ML250/500K/KS	PT005-8	RT010S-P00AP	GT010-8-10	RT010S-G08AP	RT010S-307AP
ML1000K/S	PT010-8	RT010S-P00AP	GT010-8-10	RT010S-G08AP	RT010S-307AP
MLKR (All)	PT005-8SB	RT010B-P00AP	GT010-8-10SB	RT010S-G08AP	RT010S-307AP
HL1000K	PT010-8	TIR6600S-P00AP	GT010-8-10	TIR6600S-G08AP	TIR6600S-307AP
HL1000KR	PT010-8SB	TIR6600B-P00AP	GT010-8-10SB	TIR6600B-G08AP	TIR6600B-307AP
HL1500K	PT020-8	TIR6600S-P00AP	GT020-8-10	TIR6600S-G08AP	TIR6600S-307AP
HL2000K	PT020-8	TIR6600S-P00AP	GT020-8-10	TIR6600S-G08AP	TIR6600S-307AP
HL3000K	PT030-8	TIR6600S-P00AP	GT030-8-10	TIR6600S-G08AP	TIR6600S-307AP
PAL 1/4 & 1/2t	PT005-8	RT010S-P00AT	GT010-8-10	RT010S-G08AT	RT010S-307AT
PAL 1t	PT010-8	RT010S-P00AT	GT010-8-10	RT010S-G08AT	RT010S-307AT
HL4500K	PT050-8	TIR132S-P00AP	GT050-8-10	TIR132S-G08AP	TIR132S-307AP
HL6000K	TIR132S-P00H	TIR132S-P00AP	GT050-8-10	TIR132S-G08AP	TIR132S-307AP

Note:

- (1) If trolley fits directly to the standard hoist lug mount, an adapter is not included.
- (2) If converting from hook mount, adaptors must be added in the model configuration.

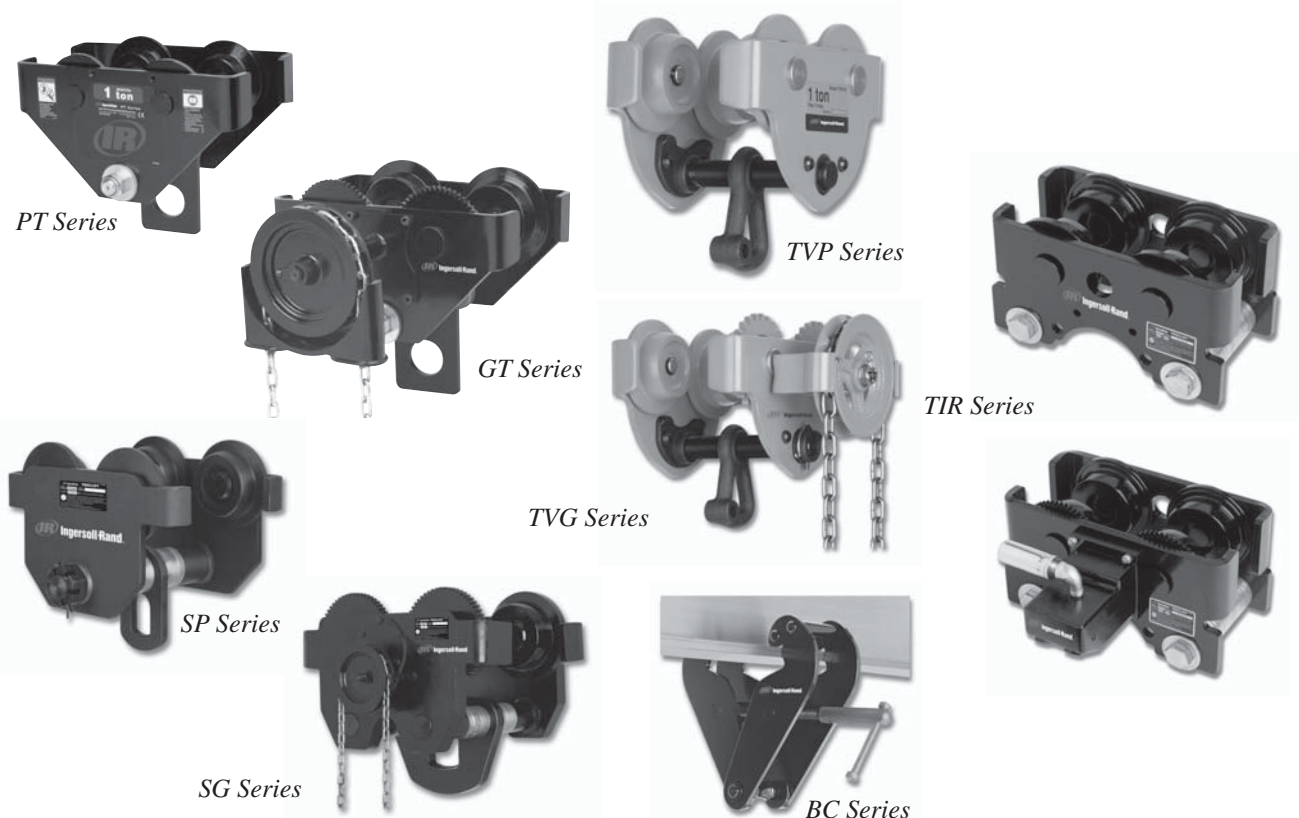

1/2 – 20 metric ton Capacity

Features

PT plain and GT hand geared hook-on style trolley rated for manual or powered hoists having the versatility to fit most types of beams with compatibility to all hoist brands.

- The 5:1 design factor allows use with both manual or powered hoists. Meets pertinent U.S. (ASME/ANSI and CMAA), Canadian and European standards.
- The side plates, including the rail sweeps/drop stops, are made of cold formed steel for strength, durability and even load distribution.
- The wheels are cast iron with the “Universal” tread fits either flat or tapered beams.
- Wheels run on sealed, “Lube-for-Life” ball bearings. Smoother rolling with less effort and maintenance.

Options:

- FDA approved nickel composite plated finish for corrosion resistance.
- Solid Bronze alloy wheels for maximum spark resistance.
- Wider hanger shaft capabilities allow standard trolleys fit almost any S-Beam or patented track beam. **Extension shaft kits are stocked.**
- Additional gearing in the 20 ton trolley allows operation by one hand chain.
- Painted black for “Universal” coordination with hoists of all colors.



PT and GT Hook-On Trolley Specifications

Model No.	Capacity tons	Capacity lbs	Flange adjustment in.	Min. beam height in.	Min. curve radius in.	Weight lbs	Kit no. (Order separate)	Flange Adjustment in.	Weight lbs
Standard Series									
PT005-8	1/2	1100	2.63-8.00	4	36	19.7	PT005-WFK	8-13	5.5
PT010-8	1	2200	3.00-8.00	5	36	30.7	PT010-WFK	8-13	9.5
GT010-8-10	1	2200	3.00-8.00	5	36	43.7	PT010-WFK	8-13	9.5
PT020-8	2	4400	3.32-8.00	6	48	60.5	PT020-WFK	8-13	10
GT020-8-10	2	4400	3.32-8.00	6	48	73.5	PT020-WFK	8-13	10
PT030-8	3	6600	3.94-8.00	7	42	73.2	PT030-WFK	8-13	16.3
GT030-8-10	3	6600	3.94-8.00	7	42	86.2	PT030-WFK	8-13	16.3
PT050-8	5	11000	4.64-8.00	8	60	110.3	PT050-WFK	8-13	24.8
GT050-8-10	5	11000	4.64-8.00	8	60	123.3	PT050-WFK	8-13	24.8
PT100-12	10	22000	7.00-13	10	83	205	NA	NA	NA
GT100-12-10	10	22000	7.00-13	10	83	227	NA	NA	NA
GT200-12	20	44000	7.00-13	12	138	540	NA	NA	NA

1/2 – 20 metric ton Capacity

PT and GT Hook-On Trolley Dimensions (in.)																			
Model no.	A	A (-8)	B	C	D	E	F	G	H	J	K	L	M	N	P	P (-8)	R	S	T
PT005-8	2.63	5.88	10	4.5	1	4	1.13	3.5	2.06	0.75	0.75	6.63	---	3.94	---	12.25	1.25	1.56	---
PT010-8	2.5	5.94	13	5.19	1.25	4.44	1.56	4.19	2.75	0.75	1	6.94	---	4.25	---	12.88	1.5	1.56	---
GT010-8-10	2.5	5.94	13	5.19	1.25	4.44	1.56	4.19	2.75	0.75	1	6.94	---	4.25	---	12.88	1.5	1.56	7.81
PT020-8	2.56	6.06	14.94	6.75	1.25	5.25	1.25	5.81	4.25	1.13	1.19	7.5	---	4.31	---	13.81	1.5	1.56	---
GT020-8-10	2.56	6.06	14.94	6.75	1.25	5.25	1.25	5.81	4.25	1.13	1.19	7.5	---	4.31	---	13.81	1.5	1.56	7.75
PT030-8	2.56	7.88	14	6.38	1.56	5.5	1.56	5.75	4.5	1.13	1.44	8.56	---	5.38	---	14.13	1.94	2.56	---
GT030-8-10	2.56	7.88	14	6.38	1.56	5.5	1.56	5.75	4.5	1.13	1.44	8.56	---	5.38	---	14.13	1.94	2.56	8.06
PT050-8	2.81	8.13	15.5	7.06	1.56	5.75	2.19	6.19	4.5	1.56	1.44	9.81	---	6.63	---	15.63	2.5	2.56	---
GT050-8-10	2.81	8.13	15.5	7.06	1.56	5.75	2.19	6.19	4.5	1.56	1.44	9.81	---	6.63	---	15.63	2.5	2.56	8.5
PT100-12	11.79	---	17.91	19.29	20.79	5.02	7.87	2.00	7.44	5.94	4.21	1.77	3.23	17.09	3.70	---	1.00	---	---
GT100-12-10	11.79	---	17.91	19.29	20.79	5.02	7.87	2.00	7.44	5.94	4.21	1.77	3.23	17.09	3.70	---	1.00	---	---
GT200-12-10	10.47	---	25.28	24.49	22.52	6.73	11.81	2.60	10.79	7.87	5.91	2.76	4.33	18.03	4.49	---	4.92	---	---

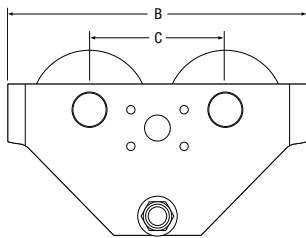

PT010 - PT050
 plain trolley / without lug

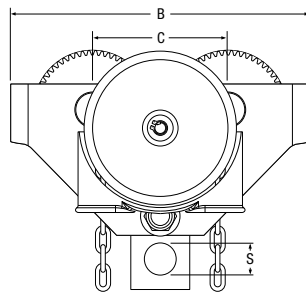

GT010 - GT050
 geared trolley

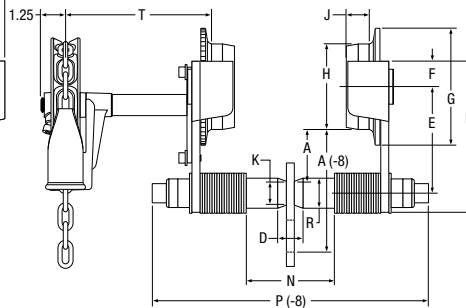

PT010 - PT050 & GT010 - GT050
 plain & geared trolley

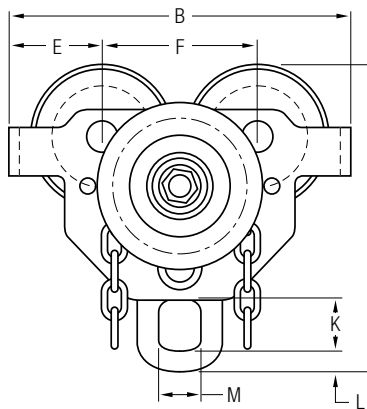

GT100
 geared trolley

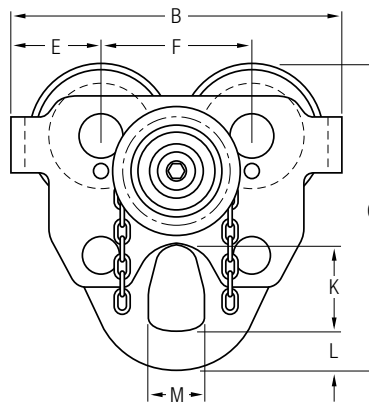

GT200
 geared trolley

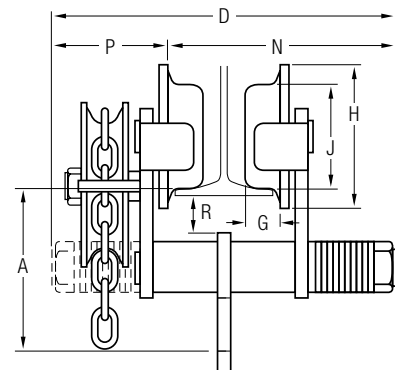

GT100 and GT200
 geared trolley

1/2 – 10 metric ton Capacity

Features:

Our “TVP” Plain and “TVG” Geared premium grade, universal trolleys offer unique features for the safe, smooth transport of loads on all types of beams.

- Patented, quick adjustable, “Threaded Bolt” suspension shaft fits a wide variety of beam widths. No hand tools are required to assemble and adjust the trolley.
- Trolley wheels and side plates rotate freely on the threaded suspension shaft. This allows the trolley to maintain an even load on all four wheels, even if the wheels encounter irregularities such as welded joints on the beam surface.
- The suspension shaft holders also serve to prevent wheel-flanges from “running up” on the rail surface.
- Design factor of 5:1 allows TVP and TVG to be used with both manual and powered hoists per ANSI B30.16.
- The suspension shaft stopper pin is firmly held by a clamp which assures safe operation as well as easy installation.
- Unique suspension lug allows either standard hook-on or **direct mounting to the MCH5 and VL2 chain hoist using the top hook pin**. This provides a more rigid mounting and saves headroom. (1/2 through 2 ton models only)
- Universal solid cast wheels fit both flat and tapered beams.
- Steel side plates incorporate integral bumpers which also serve as drop stops.
- Industrial grade, maintenance free, sealed ball bearings are used in all trolley wheels for smoother operation with less effort.



TVP Series Geared Trolley



TVG Series Geared Trolley

TVP/TVG Trolley Series Specifications

Model no.	Capacity		Standard flange adjustment in.	Minimum beam height in.	Minimum curve radius in.	Net weight TVP / TVG lbs
	metric tons	lbs				
TVP005	1/2	1100	2 ³ / ₈ – 4 ¹⁵ / ₁₆	3 ¹⁵ / ₁₆	35 ⁷ / ₁₆	13.2 / na
TVP/G010	1	2200	2 ³ / ₈ – 4 ¹⁵ / ₁₆	4 ¹⁵ / ₁₆	51 ³ / ₁₆	22 / 30.8
TVP/G020	2	4400	2 ¹⁵ / ₁₆ – 6 ¹ / ₈	5 ²⁹ / ₃₂	59 ¹ / ₁₆	40.7 / 51.7
TVP/G030	3	6600	3 ⁵ / ₃₂ – 6 ¹¹ / ₁₆	6 ⁵⁷ / ₆₄	78 ³ / ₄	57.2 / 73.7
TVP/G050	5	11000	3 ¹⁵ / ₁₆ – 6 ⁷ / ₈	7 ⁷ / ₈	102 ³ / ₈	96.8 / 117.7
TVP/G100	10	22000	5 ²⁹ / ₃₂ – 6 ⁷ / ₈	7 ⁷ / ₈	(1)	211.2 / 222.2

Note:

(1) TVP100 and TVG100 is a two trolley system. Curved track is not recommended.

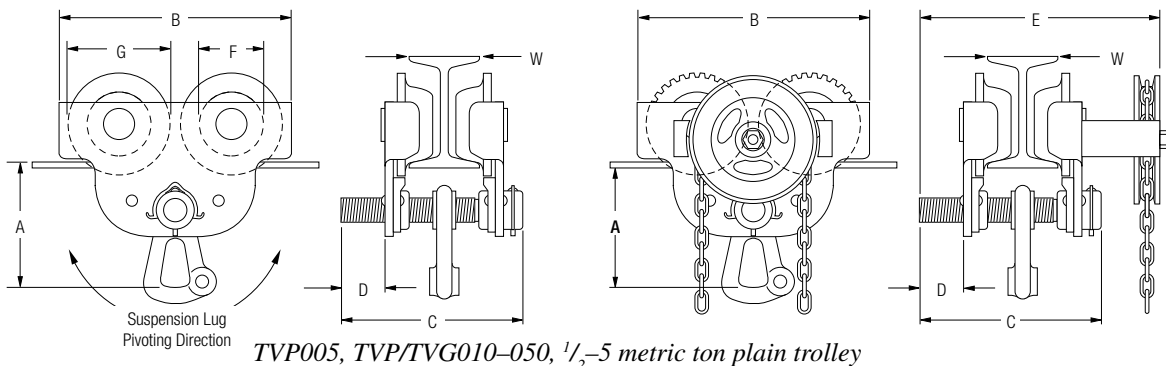

TVP/TVG Trolley Series Dimensions (in.)

Model no.	A	B	C	D ¹	E ²	F	G
TVP005	4 ³ / ₄	7 ²³ / ₃₂	7 ¹ / ₂	4 ¹⁵ / ₁₆	–	2 ³ / ₁₆	3 ⁵ / ₁₆
TVP/G010	4 ⁷ / ₈	10	7 ¹ / ₂	4 ¹⁵ / ₁₆	10 ¹ / ₂	3 ⁵ / ₃₂	4 ⁵ / ₁₆
TVP/G020	4 ⁷ / ₈	11 ¹³ / ₁₆	9 ¹ / ₈	6 ¹ / ₈	11 ¹⁵ / ₁₆	3 ¹⁵ / ₁₆	5 ³ / ₃₂
TVP/G030	7 ¹ / ₁₆	13 ³ / ₈	10 ⁵ / ₃₂	6 ¹¹ / ₁₆	13 ¹¹ / ₃₂	4 ⁷ / ₁₆	5 ⁷ / ₈
TVP/G050	7 ⁷ / ₈	15 ¹ / ₁₆	10 ⁵ / ₈	6 ⁷ / ₈	13 ⁵ / ₈	4 ¹⁵ / ₁₆	6 ²¹ / ₃₂
TVP/G100	7 ⁷ / ₈	31 ¹ / ₈	10 ⁵ / ₈	6 ⁷ / ₈	13 ⁵ / ₈	4 ¹⁵ / ₁₆	6 ²¹ / ₃₂

Notes:

- (1) “D” dimension is equal to the dimension shown minus the beam flange width.
- (2) “E” dimension applies to geared (TVG) trolleys only.

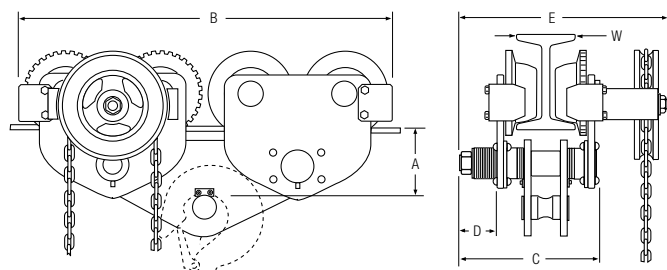

Industrial Lifting Equipment

RT and TIR Series Trolley

1/4 – 6 metric ton Capacity

Features

RT and TIR trolleys are supplied as standard equipment for MLK, HLK and Palair hoists when specified. The TIR trolley may also be used as a hook-on trolley with any hoist..

- Meets ANSI B30.16 for hoisting requirements - 5:1 safety factor (minimum).
- All steel construction.
- Universal wheels fit both flat and tapered beam flanges.
- Rail sweeps are integral with the side plates.
- Cast iron wheels roll easily on permanently greased sealed bearings.
- 7 ft pendent control or 8 ft hand chain length.
- Tight turning radius.
- Standard 3 ton trolley fits 3¹/₄ - 6 in. flange width, 6 ton a 4¹/₄ - 7¹/₄ in. flange width.
- Modular trolley frame allows conversions for hook-on, plain rigid, geared and motorized configurations in the field.
- Motorized trolley has automatic disc brake to control stopping.
- Low air consumption uses only 35 scfm for motorized version.

Options

- Bronze wheels.
- Wide flange kit for 3 ton fits beam flange widths from 6 – 12 in.
- Hook-on adapters.

RT and TIR Trolley Series Specifications

Trolley type	Min.curve radius (in.)	Standard flange adjustment(in.)	Trolley weight (lbs)
RT Trolley Series (1 metric ton maximum capacity)			
Plain rigid	28	2.66 - 6	31
Geared rigid	53	2.66 - 6	31
Motorized	55	2.66 - 6	31
TIR6600 Trolley Series (3 metric ton maximum capacity)			
Plain hook-on	42	3.25 - 6	31
Plain rigid	42	3.25 - 6	34
Geared hook-on	42	3.25 - 6	34
Geared rigid	42	3.25 - 6	37
Motorized	42	3.25 - 6	35
Plain	42	3.25 - 6	25
TIR132 Trolley Series (6 metric ton maximum capacity)			
Plain hook-on	60	4.25 - 7.25	154
Plain rigid	60	4.25 - 7.25	150
Geared hook-on	60	4.25 - 7.25	157
Geared rigid	60	4.25 - 7.25	153
Motorized	60	4.25 - 7.25	155

Motorized trolley specifications

Hoist capacity		Trolley speed on beam ¹
metric tons	lbs	
1/4	550	95
1/2	1100	93
1	2200	88
1 1/2	3300	84
2	4400	80
3	6600	71
4 1/2	9900	60
6	12000	45

Note:

(1) Beam in good condition

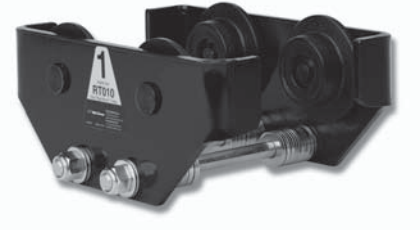

RT plain trolley



TIR6600 plain trolley



TIR6600 motorized trolley



TIR6600 hook-on adapter



MLK rigid lug adapter

1/4 – 6 metric ton Capacity

RT, TIR6600 and TIR132 Dimensions

RT Plain Rigid, Geared Rigid and Motorized Trolley

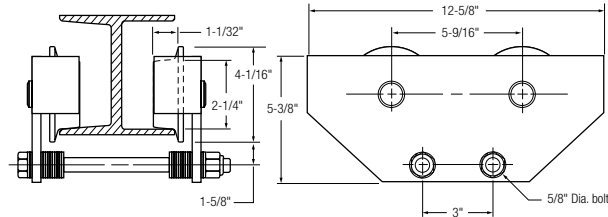

TIR6600 Plain, Geared and Lug Mounted Trolley

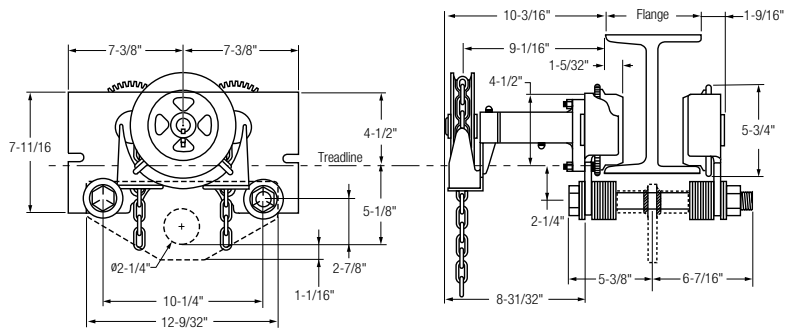

TIR6600 Motorized Trolley

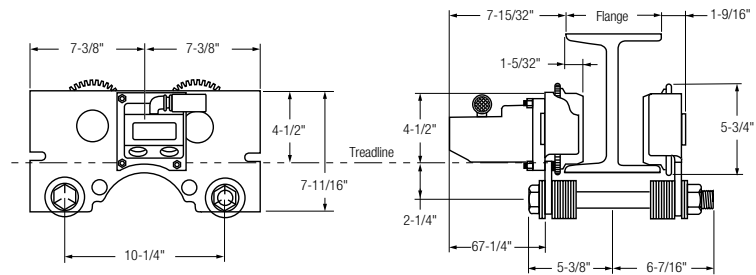

TIR132 Plain, Geared and Hook Mounted Trolley

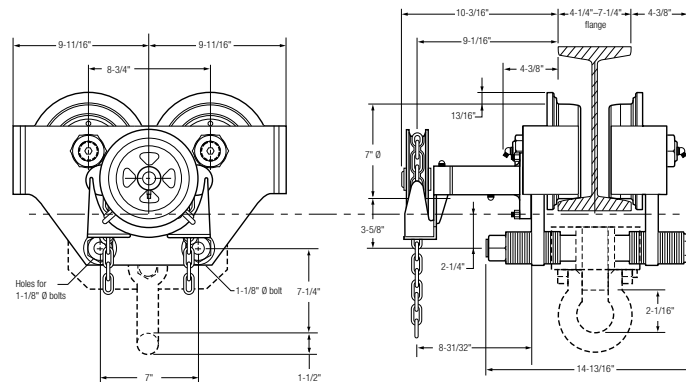

TIR132 Motorized Trolley

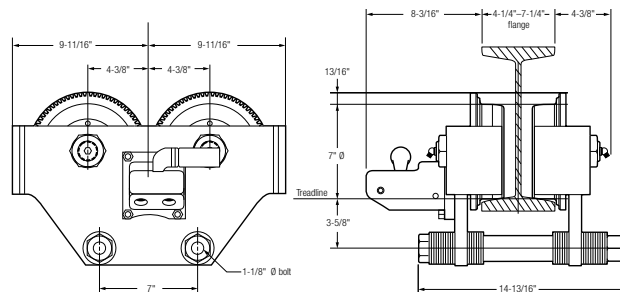

Industrial Lifting Equipment

BC Series Beam Clamp

1 – 10 metric ton Capacity

Beam Clamp features:

Beam Clamps provide a temporary or permanent mount to a wide range of tapered or flat beams. These units have been designed and verified, by actual pull testing, to achieve minimum design factor of 5:1 for vertical lifting with powered or manual hoist meeting ASME B30.16. Quick and simple installation is achieved by hand without tools. Units accommodate hook-mounted hoist or load blocks with minimal loss of headroom. The clamp jaws are designed to reduce beam stress by applying the load inside of the flange edge.

- Quick installation by hand.
- Low headroom design adjust to fit a wide range of flat or tapered beams.
- Meets ASME B30.16 for use with powered or manual hoists.
- Each unit is serialized, supplied with a test certificate and manual.
- Metric rated for vertical lifting at 2200 lbs per ton.



BC Series Beam Clamp specifications and dimensions (in.)

Model no.	Capacity metric tons	Weight lbs	Beam width					
			A	B	C	D	E	F
BC-1	1	4	2 ¹⁵ / ₁₆ - 9 ¹ / ₁₆	3 ³ / ₁₆	8 ³ / ₄	4 - 6 ⁵ / ₁₆	1 ¹ / ₈	1 ³ / ₁₆
BC-2	2	5	2 ¹⁵ / ₁₆ - 9 ¹ / ₁₆	3 ⁵ / ₈	8 ³ / ₄	4 - 6 ⁵ / ₁₆	1 ¹ / ₈	7/ ₈
BC-3	3	9	3 ⁵ / ₃₂ - 12 ⁵ / ₈	4 ⁵ / ₈	10 ³ / ₄	6 ⁵ / ₈ - 9 ¹ / ₂	2 ⁷ / ₁₆	1 ⁵ / ₁₆
BC-5	5	11	3 ⁹ / ₁₆ - 12 ⁵ / ₈	4 ¹³ / ₁₆	10 ³ / ₄	6 ⁵ / ₈ - 9 ¹ / ₂	2 ³ / ₈	1 ³ / ₁₆
BC-10	10	11	3 ⁹ / ₁₆ - 14 ³ / ₈	5 ¹⁵ / ₁₆	11 ¹ / ₆₄	6 ¹¹ / ₁₆ - 9 ¹ / ₄	1 ³¹ / ₃₂	1 ³⁷ / ₆₄

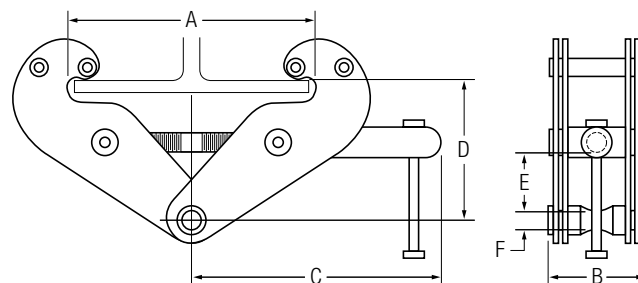

6 metric ton towing Capacity

Features

The MTK Tractor requires less air, making it less expensive to operate. Designed to be used with any hoist or even alone to push, pull or position loads on beams.

- Up to 6 metric ton towing capacity.
- Interchangeability with MLK and HLK parts.
- Balanced gear package and air motor provides a range of speed from slow creep to 165 fpm.
- Million cycle performance tested air motor with spring-loaded vanes provides instant starting and slow speed control.
- Heat treated planetary gearing assures longer life and reduced maintenance.
- Self-adjusting, spring applied, nonasbestos disc brake is air released for smooth starts and stops.
- Drive tire is made from extremely durable polyurethane material with a temperature rating of 185° F providing excellent “adjustable” gripping characteristics for positive traction.
- Tight turning radius of 30 in.
- “Universal” solid cast iron wheels will fit both flat and tapered beams.
- Wheels are greasable for longer life.
- Standard tractor fits beam flange width of 2²¹/₃₂ - 6¹/₄ in.
- Roller guides made from high alloy steel keep tractor running smoothly.
- Tractor operates with a full flow (live air) pendent enhancing load spotting control.
- 7 ft pendent length is standard.
- Tow bar included with tractor.

Options

- Free wheel kit - permits moving of tractor without supplying air to tractor. Attaches directly to tractor without modification.
- Wide flange kit - fits 6¹⁷/₆₄ - 12 in. beam flange.
- Pull chain operation.
- Bronze wheels for spark resistant applications.
- Gasket repair and manual brake release kits.
- Drawbar hitch kit (standard on all new HLKs)
- External brake release kit - air releases auto disc brake without running tractor.

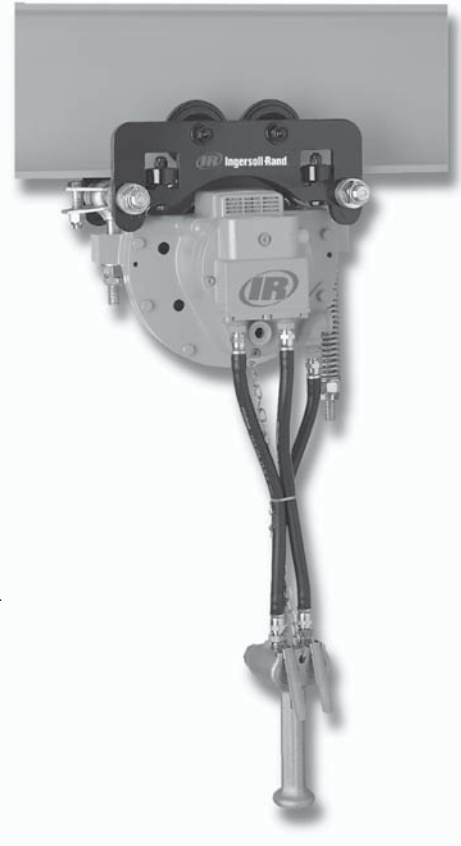

MTK Tractor Specifications¹

Drawbar pull (lbs)	Capacity/metric tons		Max speed fpm	Pendent length (ft)	Turning radius in.	Beam flange width (in.)	
	flat, dry good	curved, slick, poor				standard	optional
0	0	0	165	7	30	2 ²¹ / ₃₂ - 6 ¹ / ₄	6 ¹⁷ / ₆₄ - 12
100	1 ¹ / ₂	3/4	117	7	30	2 ²¹ / ₃₂ - 6 ¹ / ₄	6 ¹⁷ / ₆₄ - 12
200	3	1 ¹ / ₂	86	7	30	2 ²¹ / ₃₂ - 6 ¹ / ₄	6 ¹⁷ / ₆₄ - 12
300	4 ¹ / ₄	2 ¹ / ₄	57	7	30	2 ²¹ / ₃₂ - 6 ¹ / ₄	6 ¹⁷ / ₆₄ - 12
400	6	3	21	7	30	2 ²¹ / ₃₂ - 6 ¹ / ₄	6 ¹⁷ / ₆₄ - 12

Notes:

(1) At 90 psi inlet pressure. Average air consumption is 35 scfm. Range is 25 - 45 scfm depending on load and air pressure.

Draw Bar Load vs Tractor Speed

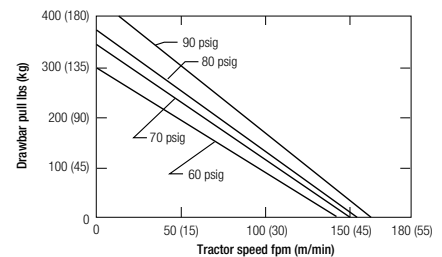

Drawbar Hitch Kits with MTK Tractor

Series hoist to be towed	Drawbar kit part no.
HL1000K, HL1500K, HL2000K and HL3000K with rigid trolley	No kit required; standard drawbar kit included with MTK tractor fits these hoists
All MLKs with rigid trolley	MR-K1
HL4500K and HL6000K	NA

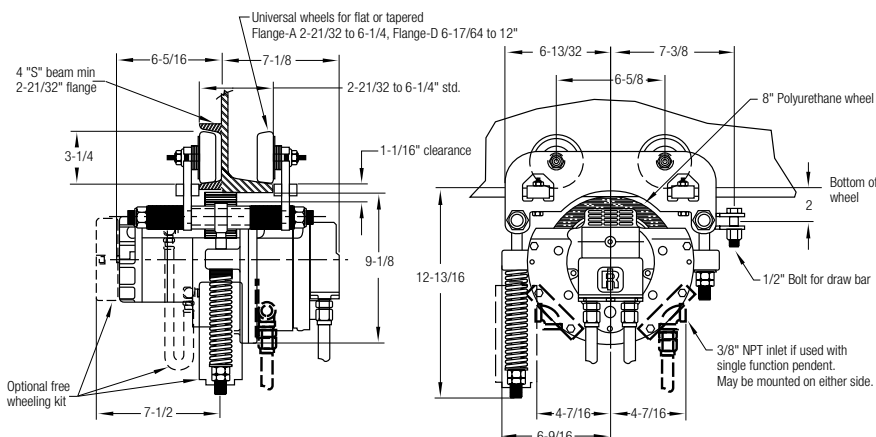

Industrial Lifting Equipment I-Beam Specifications

The following table shows the standard size (H dimension), flange widths (W dimensions) and weights for both American Standard I-beams and Wide Flange H-beams. I-beams designated with an asterisk (*) denote New Series applications which conform to ASTM A6 standards, effective September 1, 1978.

Wide Flange						American Standard					
H in.	W in.	Weight per ft/lbs	H in.	W in.	Weight per ft/lbs	H in.	W in.	Weight per ft/lbs	H in.	W in.	Weight per ft/lbs
6	3.940	8.5	10	10.117	66.0	16*	6.985	36	4	2.663	7.7
6*	4.0	9.0	10*	10.130	68.0	16	7.0	40	4	2.796	9.5
6	4.0	12.0	10	10.170	72.0	16*	6.995	40	5	3.004	10.0
6*	4.0	12.0	10	10.190	77.0	16	7.039	45	5	3.284	14.75
6	4.030	16.0	10*	10.190	77.0	16*	7.035	45	6	3.332	12.5
6*	4.030	16.0	10*	10.625	88.0	16	7.073	50	6	3.565	17.25
6*	5.990	15.0	10	10.275	89.0	16*	7.070	50	7	3.662	15.3
6	5.995	15.5	10	10.340	100.0	16*	7.120	57	7	3.860	20.0
6	6.020	20.0	10*	10.340	100.0	16	8.464	58	8	4.001	18.4
6*	6.018	20.0	10	10.415	112.0	16*	10.235	67	8	4.171	23.0
6	6.080	25.0	10*	10.415	112.0	16*	10.295	77	10	4.661	25.4
6*	6.080	25.0	12	3.968	14.0	16*	10.365	89	10	4.944	35.0
8	3.940	10.0	12*	3.970	14.0	16*	10.425	100	12	5.0	31.8
8*	3.940	10.0	12*	3.990	16.0	16	11.502	88	12	5.078	35.0
8	4.0	13.0	12	4.0	16.5	16	11.5	96	12	5.252	40.8
8*	4.0	13.0	12	4.005	19.0	18	6.0	35	12	5.477	50.0
8	4.015	15.0	12*	4.007	19.0	18*	6.0	35	15	5.501	42.9
8*	4.015	15.0	12	4.030	22.0	18	6.015	40	15	5.640	50.0
8	5.250	17.0	12*	4.030	22.0	18*	6.015	40	18	6.001	54.7
8*	5.250	18.0	12*	6.490	26.0	18*	6.060	46	18	6.251	70.0
8	5.268	20.0	12	6.497	27.0	18	7.477	45	20	6.25	65.4
8*	5.270	21.0	12*	6.520	30.0	18	7.5	50	20	6.385	75.0
8	6.495	24.0	12	6.525	31.0	18*	7.5	50	20	7.060	86.0
8*	6.5	24.0	12*	6.560	35.0	18	7.532	55	20	7.200	96.0
8	6.535	28.0	12	6.565	36.0	18*	7.530	55	24	7.001	79.9
8*	6.535	28.0	12	8.0	40.0	18	7.558	60	24	7.125	90.0
8	7.995	31.0	12*	8.005	40.0	18*	7.555	60	24	7.245	100.0
8*	7.995	31.0	12	8.042	45.0	18*	7.635	71	24	7.875	105.9
8	8.020	35.0	12*	8.045	45.0	18	8.715	64	24	8.050	121.0
8*	8.020	35.0	12	8.077	50.0	18	8.75	70			
8	8.070	40.0	12*	8.080	50.0	18	8.787	77			
8*	8.070	40.0	12	10.0	53.0	18*	11.035	76			
8	8.110	48.0	12*	9.995	53.0	18*	11.090	86			
8*	8.110	48.0	12	10.014	58.0	18*	11.145	97			
8	8.220	58.0	12*	10.010	58.0	18*	11.200	106			
8*	8.220	58.0	14	5.0	22.0	18*	11.265	119			
8	8.280	67.0	14*	5.0	22.0	18	11.75	96			
8*	8.280	67.0	14	5.025	26.0	21	6.5	44			
10	3.950	11.5	14*	5.025	26.0	21*	6.5	44			
10*	3.960	12.0	14	6.730	30.0	21*	6.530	50			
10	4.0	15.0	14*	6.730	30.0	21*	6.555	57			
10*	4.0	15.0	14	6.75	34.0	21	8.215	55			
10	4.010	17.0	14*	6.745	34.0	21	8.240	62			
10*	4.010	17.0	14	6.770	38.0	21*	8.240	62			
10	4.020	19.0	14*	6.770	38.0	21	8.270	68			
10*	4.020	19.0	14	8.0	43.0	21*	8.270	68			
10	5.75	21.0	14*	7.995	43.0	21	8.295	73			
10*	5.75	22.0	14	8.031	48.0	21*	8.295	73			
10	5.762	25.0	14*	8.030	48.0	21*	8.355	83			
10*	5.770	26.0	14	8.062	53.0	21*	8.420	93			
10	5.799	29.0	14*	8.060	53.0	21	8.962	82			
10*	5.810	30.0	14	10.0	61.0	24	7.005	55			
10	7.960	33.0	14*	9.995	61.0	24*	7.005	55			
10*	7.960	33.0	14	10.035	68.0	24*	7.040	62			
10	7.985	39.0	14	10.035	68.0	24	8.961	68			
10*	7.985	39.0	14	10.072	74.0	24*	8.965	68			
10	8.020	45.0	14*	10.070	74.0	24	8.965	76			
10*	8.020	45.0	14	12.0	78.0	24*	8.990	76			
10	10.0	49.0	14	14.5	87.0	24	9.015	84			
10*	10.0	49.0	14*	10.130	82.0	24*	9.020	84			
10	10.030	54.0	16	5.5	26.0	24	9.065	94			
10*	10.030	54.0	16	5.525	31.0	24*	9.065	94			
10	10.080	60.0	16*	5.525	31.0	-	-	-			
10*	10.080	60.0	16	6.692	36.0	-	-	-			

American Standard

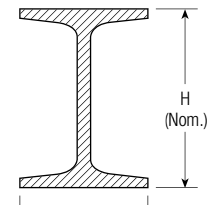

Tapered "S" Beam

Wide Flange

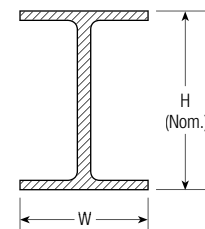

Flat "H" Beam

WARRANTY

LIFTING EQUIPMENT

Ingersoll-Rand warrants to the original user its lifting equipment products to be free of defects in material and workmanship for a period of one year from the date of purchase. IR will repair, without cost, any Product found to be defective, including parts and labor charges, or at its option, will replace such Products or refund the purchase price less a reasonable allowance for depreciation, in exchange for the Product. Repairs or replacements are warranted for the remainder of the original warranty period.

If any product proves defective within its original one year warranty period, it should be returned to an appropriate Ingersoll-Rand Service Distributor, transportation prepaid with proof of purchase or warranty card.

This warranty does not apply to Products which IR has determined to have been misused or abused, improperly maintained by the purchaser: or where the malfunction or defect can be attributed to the use of non-genuine IR parts.

IR makes no other warranty, and all implied warranties including any warranty of merchantability or fitness for a particular purpose are limited to the duration of the expressed warranty period as set for the above. IR's maximum liability is limited to the purchase price of the Product and in no event shall IR be liable for any consequential, indirect, incidental, or special damages of any nature arising from the sale or use of the Product, whether based on contract, tort, or otherwise.

Questions? Parts? Service?



**Ontario's Largest
Pneumatic & Hydraulic Tool Distributor**

1-2430 Lucknow Drive, Mississauga, Ontario L5S 1V3. Tel: 905-672-5557 Fax: 905-672-5559
Email: sales@dobcoeqp.com www.dobcoeqp.com

• • • • •

• • •

—

—